



TESTING

TESTA TT TEMPERATURE TESTING

TESTA CT CLIMATIC TESTING

'REACH-IN' ENVIRONMENTAL TEST CHAMBERS





ARALAB is a company specialised in designing, developing, manufacturing and servicing of high quality climatic chambers and controlled environment rooms.

Since 1985 we have been perfecting ways to create and control temperature, humidity, light, air flow and many other environmental conditions.

Only the highest quality components are used to manufacture our chambers so customers can have the best equipment for their research and testing purposes.

Control the Environment. Your Own Climate.



TESTA temperature and humidity testing chambers offer highly precise and reproducible conditions for climatic and temperature testing in many industries.

COMMON APPLICATIONS INCLUDE:

- ENVIRONMENTAL TESTING
- ELECTRONICS, AUTOMOTIVE, AEROSPACE,
- BUILDING MATERIALS, MILITARY EQUIPMENT, MATERIALS IN GENERAL
- RESEARCH & DEVELOPMENT
- QUALITY CONTROL
- PRODUCTION FACILITIES



Certified ISO:9001 for its Quality Management System
 Certified ISO:14001 for its Environmental Management System



KEY FEATURES

- The most advanced technology in climate control
- Internal aerodynamic optimisation to ensure uniformity of climatic conditions
- Time saving features with easily configurable testing programs that can run, start and stop automatically
- Highly resistant stainless steel interior for maximum durability and easy cleaning
- Flexible interior with height adjustable and removable stainless steel shelves
- Nonpolluting construction and cooling system
- Compliant with international standards and requirements EN, IEC, DIN, ISO, NP and UNE

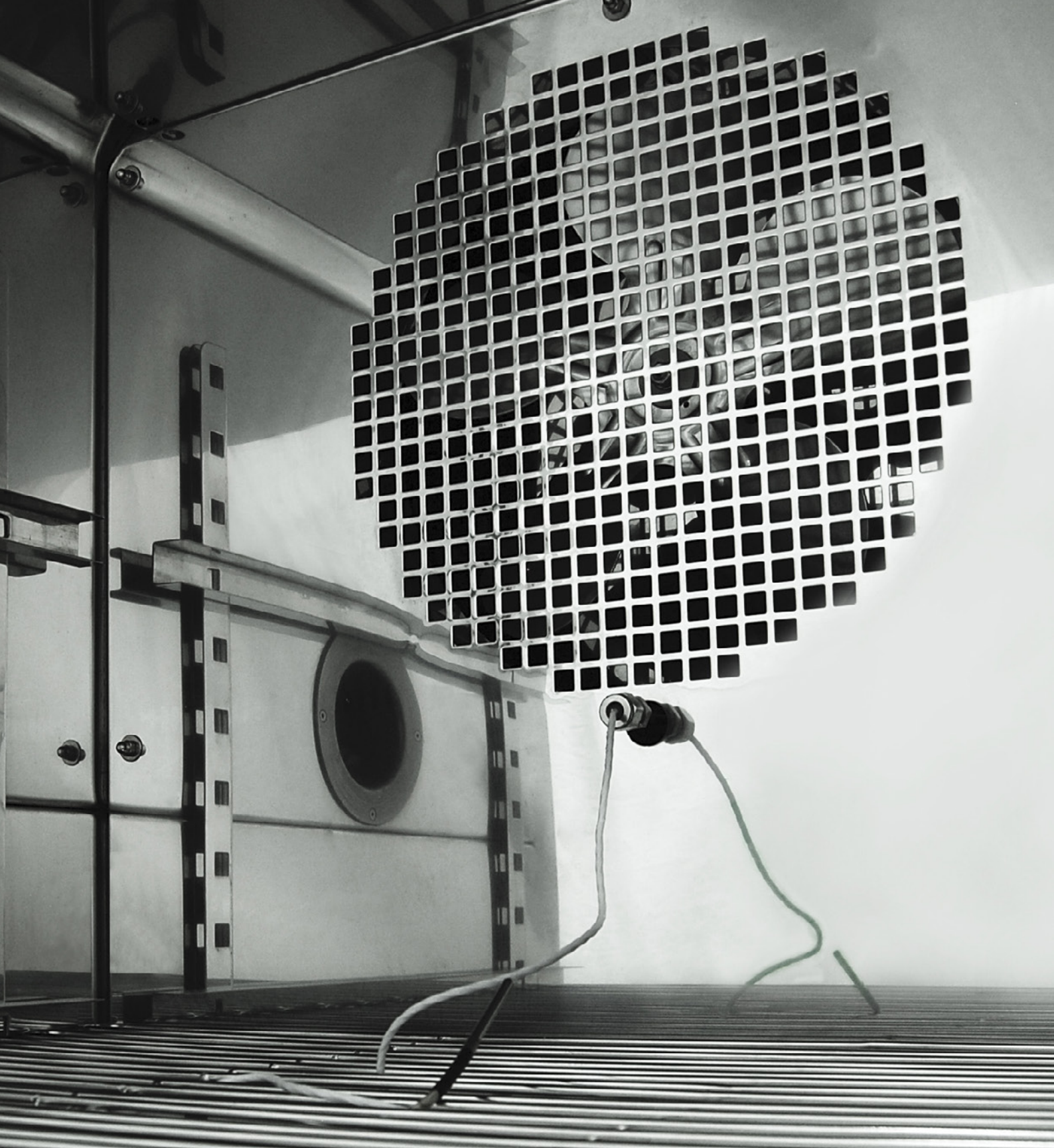

TESTA ENVIRONMENTAL CHAMBERS

TEMPERATURE AND HUMIDITY TESTING CHAMBERS BUILT
TO LAST AND MEET THE MOST DEMANDING STANDARDS.

TESTA CHAMBERS - MODELS AND REFERENCES

● ● ● ● TESTA TT CHAMBERS - TEMPERATURE ONLY

TESTA TT CHAMBERS	TEMPERATURE RANGE	HUMIDITY RANGE
TESTA TT E20	-20°C to +180°C	N/A
TESTA TT E45	-45°C to +180°C	N/A
TESTA TT E75	-75°C to +180°C	N/A

● ● ● ● TESTA CT CHAMBERS - TEMPERATURE AND HUMIDITY



TESTA CT CHAMBERS	TEMPERATURE RANGE	HUMIDITY RANGE
TESTA CT EP20, EC20 or ECP20	-20°C to +180°C	10 to 98% RH
TESTA CT EP45, EC45 or ECP45	-45°C to +180°C	10 to 98% RH
TESTA CT EP75, EC75 or ECP75	-75°C to +180°C	10 to 98% RH

EC - models with Capacitive humidity sensor
 EP - models with Psychrometric humidity sensor
 ECP - models with both Capacitive and Psychrometric humidity sensors.
 Please consult Aralab if in doubt about the type of sensor to chose





RANGES FOR CLIMATIC AND TEMPERATURE TESTING

● ● ● ● TESTA CT TESTING CHAMBERS

Performance in CLIMATIC testing range | only TESTA CT chambers

TEMPERATURE RANGE		10°C to 90°C
TEMPERATURE UNIFORMITY		± 0,1°C to ± 1,0°C ^(1b)
HUMIDITY RANGE		10% RH to 98% RH

Performance in TEMPERATURE testing | TESTA TT and TESTA CT chambers

TEMPERATURE RANGE		-75°C, -45°C or -20°C up to 180 °C
TEMPERATURE UNIFORMITY ^(1a)		± 0,5°C to ± 1,5°C
TEMPERATURE RATE OF CHANGE HEATING ^{(2a) (2b)}		3 versions available: Up to 5K/minute 5k/minute 10k/minute
TEMPERATURE RATE OF CHANGE COOLING ^{(2a) (2b)}		3 versions available: Up to 5K/minute 5k/minute 10k/minute (only for Testa 1.000)

Other technical data

NOISE LEVEL		55 to 64 dBA
-------------	---	--------------

Performances measured in factory with ambient temperatures between 20°C and 25°C.

(1a) Measurements at center of test space, with empty chamber and no optional accessories; (1b) in temperature range up to 150°C;

(2a) According to IEC/EN 60068-3-5. Values will vary with TESTA CT/TESTA TT model, internal volume, compressor type and condenser cooling system. Temperature rate of change can be adjusted to comply with the needed heating / cooling speed requirements. Optional accessories are available for more demanding heating and cooling temperature change rates.

DIMENSIONS AND DRAWINGS

● ● ● ● SYSTEM STRUCTURE

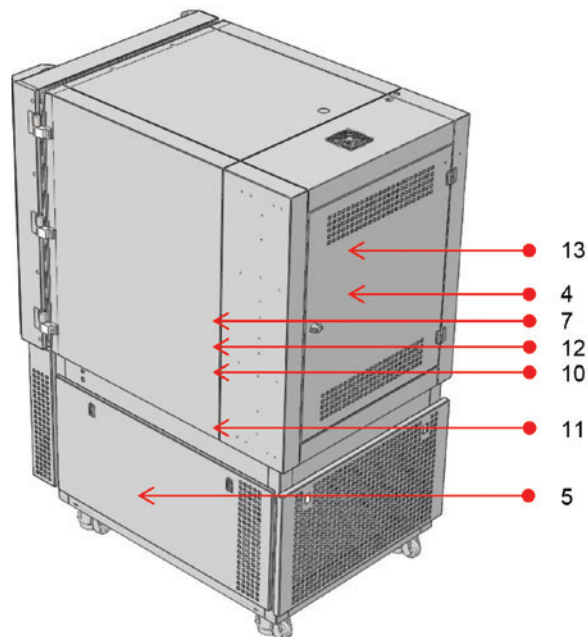
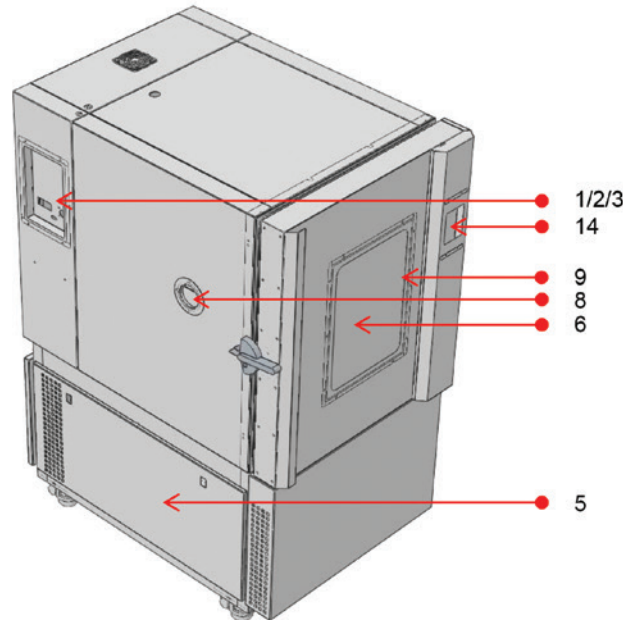

1. Main switch
2. DB9 connector
3. Safety thermostat
4. Powerhouse
5. Machinery compartment
6. Observation Window (optional)
7. Sensors

8. Entry-port Ø80
9. Interior Light (with optional observation window)
10. Evaporator
11. Dew point bath
12. Heater
13. Ventilation
14. Touch screen controller

TESTA 300 - PERFORMANCES, DIMENSIONS AND DRAWINGS

● ● ● ● TESTA TT / TESTA CT 300

EXTERNAL DIMENSIONS (HxWxD) (mm)		1.840 x 1.009 x 1.350
INTERNAL DIMENSIONS (HxWxD) (mm)		715 x 634 x 600

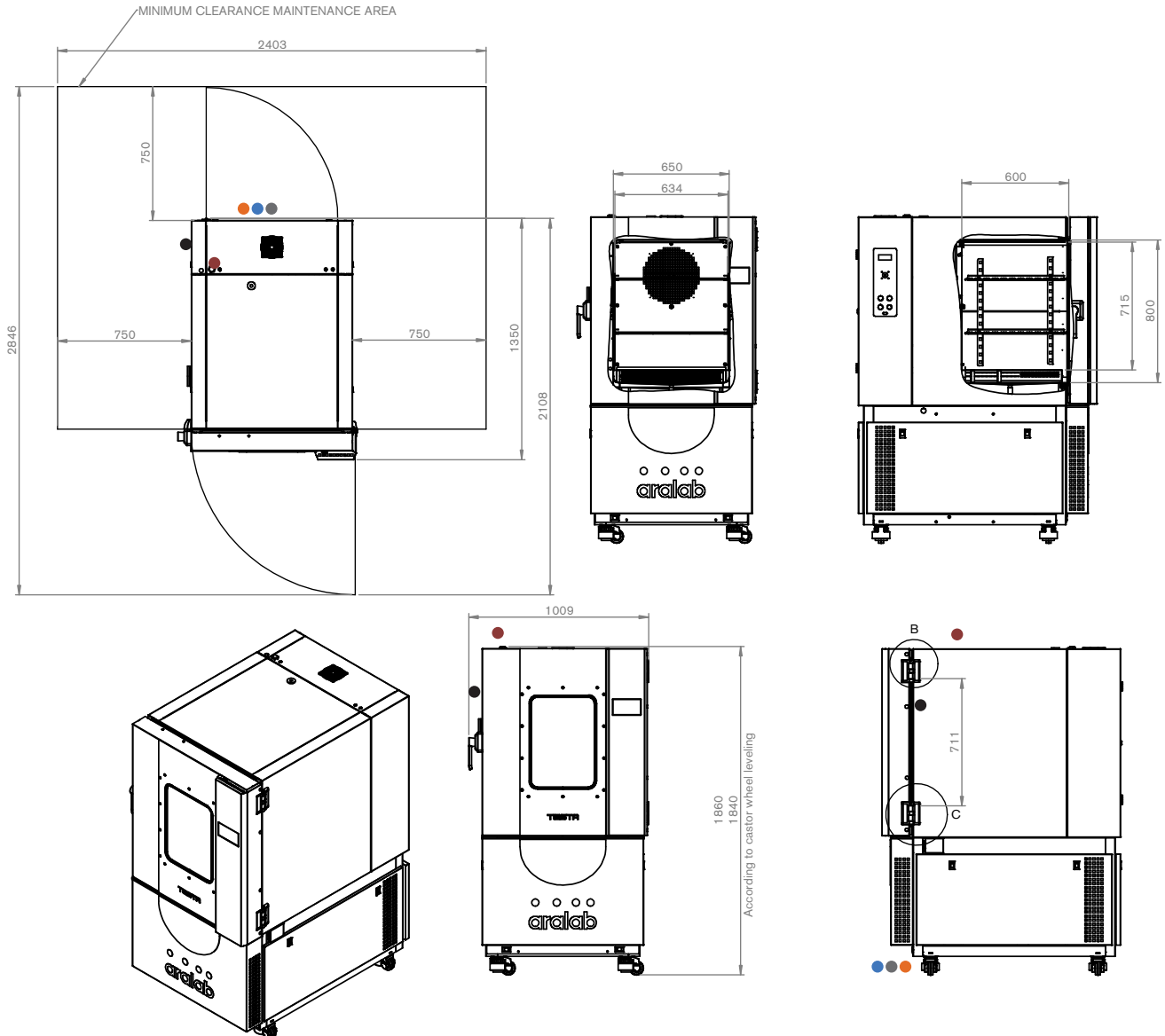

1. **Standard refrigeration system is air cooled**

2. **Services hub installation needs:**

- 1/2" demineralized water supply
- Conductivity: <math>< 50 \mu\text{S}/\text{cm}</math>
- 50mm water drain at floor level

3. **Electrical cabinet installation needs:**

Supply power ECP20:

230VAC, 50Hz, 16A / Single Phase + Neutral + Ground
Electrical protection: Circuit breaker 16A + N with 300mA differential
Single Phase electrical cable RV-K 3G2,5 on the top

Supply power ECP45:

400VAC, 50Hz, 16A / 3-Phase + Neutral + Ground
Electrical protection: Circuit breaker 3 x 16A + N with 300mA differential
3-Phase electrical cable RV-K 5G4 on the top

Supply power ECP75:

400VAC, 50Hz, 20A / 3-Phase + Neutral + Ground
Electrical protection: Circuit breaker 3 x 32A + N with 300mA differential
3-Phase electrical cable RV-K 5G10 on the top

4. **RJ45 communications port**

● **Water cooled option (is included as standard in -75°C models, 5k and 10k models)**

Water flow: up to 2000 l/hr (at 25 °C)
Intake pressure: 2 to 5 bar
Water entry and exit pipe: 1" or 28mm
Differential pressure between entry and exit: $\geq 2,5$ bars
Maximum temperature of water entry: 26 °C
Minimum temperature of water entry: 16 °C
Recommended temperature of water entry: 18 °C

TESTA CHAMBERS PERFORMANCE	units	Testa TT 300 -20	Testa CT 300 -20	Testa TT 300 -45	Testa CT 300 -45	Testa TT 300 -40 5K	Testa CT 300 -40 5K	Testa TT 300 -75	Testa CT 300 -75
PERFORMANCE IN TEMPERATURE TESTING									
Temperature range									
Min	°C	-20	-20	-45	-45	-40	-40	-75	-75
Max	°C	180	180	180	180	180	180	180	180
Temperature uniformity (1a) (1b)									
in Space @ low temp. point	°C	± 0,5	± 0,5	± 0,8	± 0,7	± 0,8	± 0,7	± 0,7	± 1,3
in Space @ +25°C	°C	± 0,2	± 0,2	± 0,1	± 0,2	± 0,1	± 0,2	± 0,2	± 0,2
in Space @ high temp point	°C	± 1,2	± 1,5	± 1,1	± 1,5	± 1,1	± 1,5	± 1,1	± 1,5
Max. According to IEC60068-3-5	°C	± 1,5							
Temperature fluctuation in time	°C	± 0,1°C to ± 0,3°C							
Temperature change rate (2a)									
cooling	K/min	2	2	3	3	5	5	3,5	3,5
heating	K/min	2	2	5	5	5	5	5	5
PERFORMANCE IN HUMIDITY TESTING									
Humidity range									
Min	%rH	-	10	-	10	-	10	-	10
Max	%rH	-	98	-	98	-	98	-	98
Humidity uniformity IEC60068-3-5 (1a) (1b)									
in space	%rH	-	± 2	-	± 2	-	± 2	-	± 2
Fluctuation in time	%rH	-	± 1	-	± 1	-	± 1	-	± 1
DIMENSIONS									
Test space volume	liters	272							
Shelves									
number of shelves included (more can be added)	#	2							
maximum weight load per shelf	kg	25							
Entry ports									
Included as standard (more can be added)	units	1							
Diameter (other diameters available)	mm	Ø80							
Weight (approximately)	Kg	470		535		535		540	
POWER & REFRIGERATION									
Supply voltage	V	1/N/PE 230V±10% 50Hz-60Hz				3/N/PE AC 400V±10% 50Hz-60Hz			
Nominal Power	kW	4	4	11	11	11	11	22	22
Type of Refrigeration (air or water cooled)									
Air		Standard				Optional			
Water		Optional				Standard			
Type of Refrigerant									
		R449A				R449A + R23			
Noise levels	dBa	55 to 64 dBA							

Performances measured in factory with ambient temperatures between 20°C and 25°C.

(1a) Measurements at center of test space, with empty chamber and no optional accessories; (1b) in temperature range up to 150°C;

(2a) According to IEC/EN 60068-3-5. Values will vary with TESTA CT/TESTA TT model, internal volume, compressor type and condenser cooling system. Temperature rate of change can be adjusted to comply with the needed heating / cooling speed requirements. Optional accessories are available for more demanding heating and cooling temperature change rates.

TESTA 500 PERFORMANCES, DIMENSIONS AND DRAWINGS

● ● ● ● TESTA TT / TESTA CT 500

EXTERNAL DIMENSIONS (HxWxD) (mm)		1.960 x 1.059 x 1.540
INTERNAL DIMENSIONS (HxWxD) (mm)		830 x 680 x 770

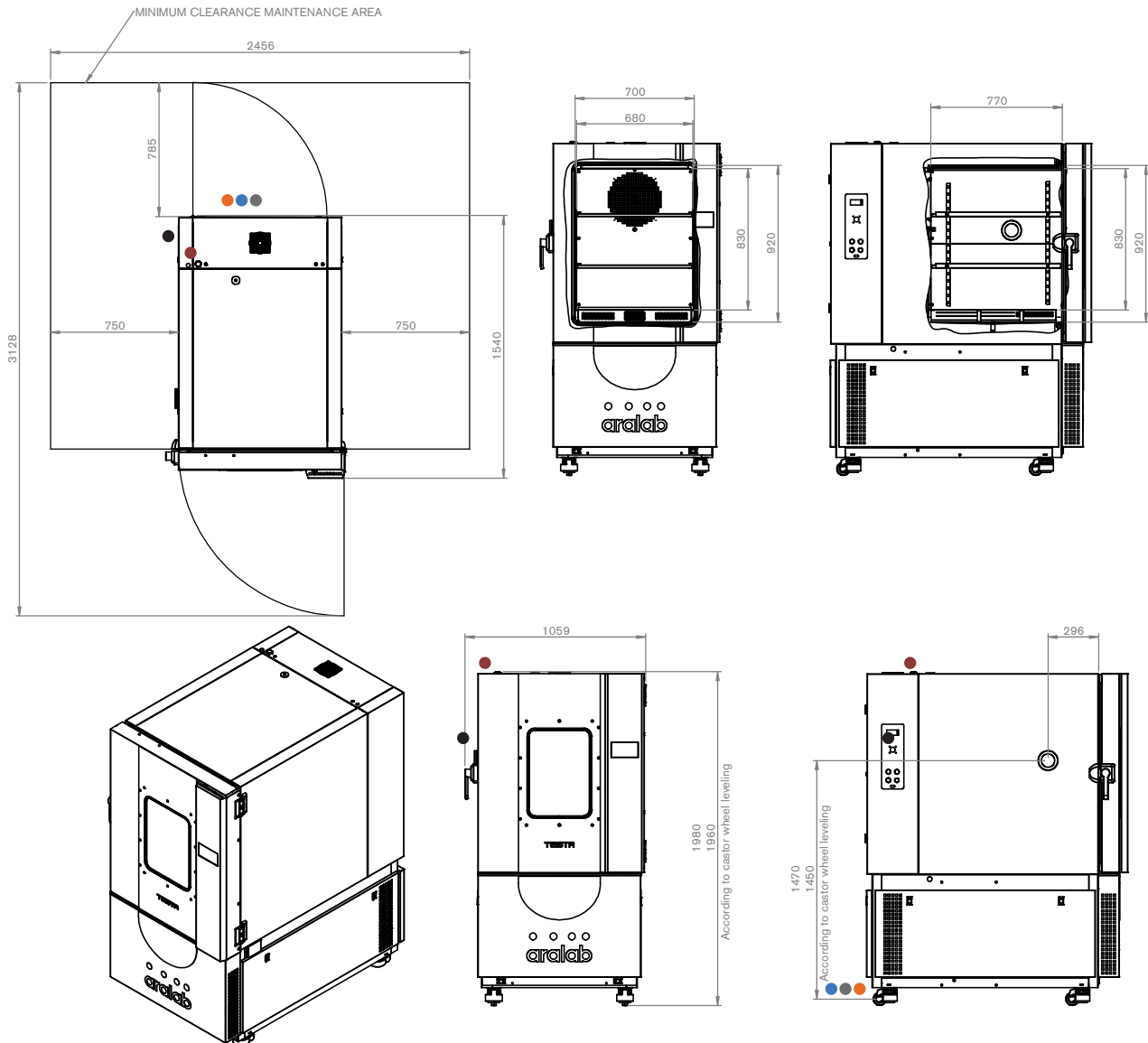

- | | |
|---|---|
| <ol style="list-style-type: none"> 1. Standard refrigeration system is air cooled 2. Services hub installation needs: <ul style="list-style-type: none"> ● 1/2" demineralized water supply Conductivity: <math>< 50 \mu\text{S}/\text{cm}</math> ● 50mm water drain at floor level 3. Electrical cabinet installation needs: <p>Supply power ECP20:
400VAC, 50Hz, 16A / 3-Phase + Neutral + Ground
Electrical protection: Circuit breaker 3 x 16A + N with 300mA differential
Single Phase electrical cable RV-K 5G2,5 on the top</p> <p>Supply power ECP45:
400VAC, 50Hz, 16A / 3-Phase + Neutral + Ground
Electrical protection: Circuit breaker 3 x 16A + N with 300mA differential
3-Phase electrical cable RV-K 5G4 on the top</p> | <ol style="list-style-type: none"> 4. Supply power ECP75:
400VAC, 50Hz, 20A / 3-Phase + Neutral + Ground
Electrical protection: Circuit breaker 3 x 32A + N with 300mA differential
3-Phase electrical cable RV-K 5G10 on the top ● RJ45 communications port ● Water cooled option (is included as standard in -75°C models, 5k and 10k models)
Water flow: up to 2000 l/hr (at 25 °C)
Intake pressure: 2 to 5 bar
Water entry and exit pipe: 1" or 28mm
Differential pressure between entry and exit: $\geq 2,5$ bars
Maximum temperature of water entry: 26 °C
Minimum temperature of water entry: 16 °C
Recommended temperature of water entry: 18 °C |
|---|---|

TESTA CHAMBERS PERFORMANCE	units	Testa TT 500 -20	Testa CT 500 -20	Testa TT 500 -45	Testa CT 500 -45	Testa TT 500 -40 5K	Testa CT 500 -40 5K	Testa TT 500 -75	Testa CT 500 -75
PERFORMANCE IN TEMPERATURE TESTING									
Temperature range									
Min	°C	-20	-20	-45	-45	-40	-40	-75	-75
Max	°C	180	180	180	180	180	180	180	180
Temperature uniformity (1a) (1b)									
in Space @ low temp. point	°C	± 0,5	± 0,5	± 0,6	± 0,6	± 0,6	± 0,6	± 1,2	± 0,7
in Space @ +25°C	°C	± 0,1	± 0,1	± 0,2	± 0,2	± 0,2	± 0,2	± 0,1	± 0,1
in Space @ high temp point	°C	± 1,4	± 1,4	± 1,5	± 1,5	± 1,5	± 1,5	± 1,3	± 1,3
Max. According to IEC60068-3-5	°C	± 1,5							
Temperature fluctuation in time	°C	± 0,1°C to ± 0,3°C							
Temperature change rate (2a)									
cooling	K/min	3,5	3,5	3	3	5	5	3,5	3
heating	K/min	4,5	4,5	4,5	4,5	4,5	4,5	4,5	4,5
PERFORMANCE IN HUMIDITY TESTING									
Humidity range									
Min	%rH	-	10	-	10	-	10	-	10
Max	%rH	-	98	-	98	-	98	-	98
Humidity uniformity IEC60068-3-5 (1a) (1b)									
in space	%rH	-	± 2	-	± 2	-	± 2	-	± 2
Fluctuation in time	%rH	-	± 1	-	± 1	-	± 1	-	± 1
DIMENSIONS									
Test space volume	liters	455							
Shelves									
number of shelves included (more can be added)	#	2							
maximum weight load per shelf	kg	25							
Entry ports									
Included as standard (more can be added)	units	1							
Diameter (other diameters available)	mm	Ø80							
Weight (approximately)	Kg	572		584		584		600	
POWER & REFRIGERATION									
Supply voltage	V	3/N/PE AC 400V±10% 50Hz-60Hz							
Nominal Power	kW	11	11	11	11	11	11	22	22
Type of Refrigeration (air or water cooled)									
Air		Standard							Optional
Water		Optional							Standard
Type of Refrigerant		R449A							R449A + R23
Noise levels	dBA	55 to 64 dBA							

Performances measured in factory with ambient temperatures between 20°C and 25°C.

(1a) Measurements at center of test space, with empty chamber and no optional accessories; (1b) in temperature range up to 150°C;

(2a) According to IEC/EN 60068-3-5. Values will vary with TESTA CT/TESTA TT model, internal volume, compressor type and condenser cooling system. Temperature rate of change can be adjusted to comply with the needed heating / cooling speed requirements. Optional accessories are available for more demanding heating and cooling temperature change rates.

TESTA 1.000 PERFORMANCES, DIMENSIONS AND DRAWINGS

● ● ● ● TESTA TT / TESTA CT 1.000

EXTERNAL DIMENSIONS (HxWxD) (mm)		1.990 x 1.359 x 1.836
INTERNAL DIMENSIONS (HxWxD) (mm)		910 x 984 x 1.052

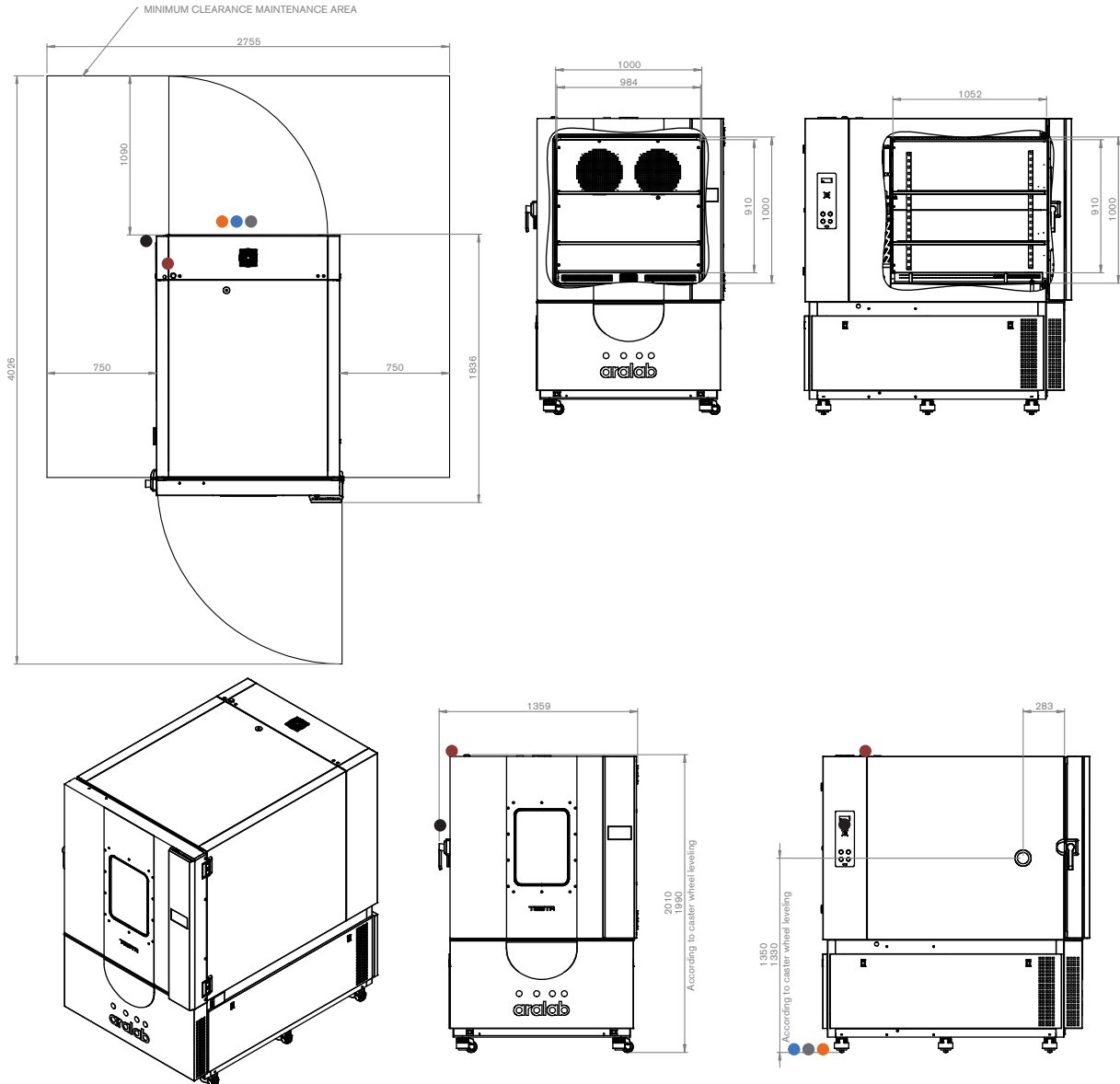

- | | |
|---|---|
| <ol style="list-style-type: none"> 1. Standard refrigeration system is air cooled 2. Services hub installation needs: <ul style="list-style-type: none"> ● 1/2" demineralized water supply Conductivity: <math>< 50 \mu\text{S}/\text{cm}</math> ● 50mm water drain at floor level 3. Electrical cabinet installation needs: <p>Supply power ECP20:
400VAC, 50Hz, 25A / 3-Phase + Neutral + Ground
Electrical protection: Circuit breaker 3 x 16A + N with 300mA differential
Single Phase electrical cable RV K 5G4 on the top</p> <p>Supply power ECP45:
400VAC, 50Hz, 32A / 3-Phase + Neutral + Ground
Electrical protection: Circuit breaker 3 x 32A + N with 300mA differential
3-Phase electrical cable RV-K 5G4 on the top</p> | <ol style="list-style-type: none"> 4. Supply power ECP75:
400VAC, 50Hz, 50A / 3 Phase + Neutral + Ground
Electrical protection: Circuit breaker 3 x 63A + N with 300mA differential
3-Phase electrical cable RV-K 5G10 on the top ● RJ45 communications port ● Water cooled option (is included as standard in -75°C models, 5k and 10k models)
Water flow: up to 2000 l/hr (at 25 °C)
Intake pressure: 2 to 5 bar
Water entry and exit pipe: 1" or 28mm
Differential pressure between entry and exit: $\geq 2,5$ bars
Maximum temperature of water entry: 26 °C
Minimum temperature of water entry: 16 °C
Recommended temperature of water entry: 18 °C |
|---|---|

TESTA CHAMBERS PERFORMANCE	units	Testa TT 1.000 -20	Testa CT 1.000 -20	Testa TT 1.000 -45	Testa CT 1.000 -45	Testa TT 1.000 -40 5K	Testa CT 1.000 -40 5K
PERFORMANCE IN TEMPERATURE TESTING							
Temperature range							
Min	°C	-20	-20	-45	-45	-40	-40
Max	°C	180	180	180	180	180	180
Temperature uniformity (1a) (1b)							
in Space @ low temp. point	°C	± 0,7	± 0,7	± 0,7	± 0,7	± 0,7	± 0,7
in Space @ +25°C	°C	± 0,2	± 0,2	± 0,3	± 0,3	± 0,3	± 0,3
in Space @ high temp point	°C	± 1,5	± 1,5	± 1,4	± 1,5	± 1,4	± 1,5
Max. According to IEC60068-3-5	°C	± 1,5					
Temperature fluctuation in time	°C	± 0,1°C to ± 0,3°C					
Temperature change rate (2a)							
cooling	K/min	4	4	4,5	4,5	5	5
heating	K/min	4,5	4,5	5	5	5	5
PERFORMANCE IN HUMIDITY TESTING							
Humidity range							
Min	%rH	-	10	-	10	-	10
Max	%rH	-	98	-	98	-	98
Humidity uniformity IEC60068-3-5 (1a) (1b)							
in space	%rH	-	± 2	-	± 2	-	± 2
Fluctuation in time	%rH	-	± 1	-	± 1	-	± 1
DIMENSIONS							
Test space volume	liters	967					
Shelves							
number of shelves included (more can be added)	#	2					
maximum weight load per shelf	kg	50					
Entry ports							
Included as standard (more can be added)	units	1					
Diameter (other diameters available)	mm	Ø80					
Weight (approximately)	Kg	800	874			874	
POWER & REFRIGERATION							
Supply voltage	V	3/N/PE AC 400V±10% 50Hz-60Hz					
Nominal Power	kW	17	17	22	22	22	22
Type of Refrigeration (air or water cooled)							
Air	Standard						
Water	Optional						
Type of Refrigerant	R449A						
Noise levels	dBA	55 to 64 dBA					

Performances measured in factory with ambient temperatures between 20°C and 25°C.

(1a) Measurements at center of test space, with empty chamber and no optional accessories; (1b) in temperature range up to 150°C;

(2a) According to IEC/EN 60068-3-5. Values will vary with TESTA CT/TESTA TT model, internal volume, compressor type and condenser cooling system. Temperature rate of change can be adjusted to comply with the needed heating / cooling speed requirements. Optional accessories are available for more demanding heating and cooling temperature change rates.

TESTA CHAMBERS PERFORMANCE	units	Testa TT 1.000 -40 10K	Testa CT 1.000 -40 10K	Testa TT 1.000 -75	Testa CT 1.000 -75
PERFORMANCE IN TEMPERATURE TESTING					
Temperature range					
Min	°C	-40 (for 10K/m cooling) and -75 (4K/m cooling)	-40 (for 10K/m cooling) and -75 (4K/m cooling)	-75	-75
Max	°C	180	180	180	180
Temperature uniformity (1a) (1b)					
in Space @ low temp. point	°C	± 0,7	± 0,7	± 1,2	± 1,2
in Space @ +25°C	°C	± 0,3	± 0,3	± 0,3	± 0,1
in Space @ high temp point	°C	± 1,5	± 1,5	± 1,5	± 1,5
Max. According to IEC60068-3-5	°C	± 1,5			
Temperature fluctuation in time	°C	± 0,1°C to ± 0,3°C			
Temperature change rate (2a)					
cooling	K/min	10	10	4	4
heating	K/min	10	10	4,5	4,5
PERFORMANCE IN HUMIDITY TESTING					
Humidity range					
Min	%rH	-	10	-	10
Max	%rH	-	98	-	98
Humidity uniformity IEC60068-3-5 (1a) (1b)					
in space	%rH	-	± 2	-	± 2
Fluctuation in time	%rH	-	± 1	-	± 1
DIMENSIONS					
Test space volume	liters	967			
Shelves					
number of shelves included (more can be added)	#	2			
maximum weight load per shelf	kg	50			
Entry ports					
Included as standard (more can be added)	units	1			
Diameter (other diameters available)	mm	Ø80			
Weight (approximately)	Kg	910		910	
POWER & REFRIGERATION					
Supply voltage	V	3/N/PE AC 400V±10% 50Hz-60Hz			
Nominal Power	kW	44	44	35	35
Type of Refrigeration (air or water cooled)					
Air		N/A		Optional	
Water		Standard		Standard	
Type of Refrigerant		R449A + R23			
Noise levels	dBA	55 to 64 dBA			

Performances measured in factory with ambient temperatures between 20°C and 25°C.

(1a) Measurements at center of test space, with empty chamber and no optional accessories; (1b) in temperature range up to 150°C;

(2a) According to IEC/EN 60068-3-5. Values will vary with TESTA CT/TESTA TT model, internal volume, compressor type and condenser cooling system. Temperature rate of change can be adjusted to comply with the needed heating / cooling speed requirements. Optional accessories are available for more demanding heating and cooling temperature change rates.

TESTA 1.500 PERFORMANCES, DIMENSIONS AND DRAWINGS

● ● ● ● TESTA TT TESTA CT 1.500

EXTERNAL DIMENSIONS (HxWxD) (mm)		2.030 x 1.359 x 2.336
INTERNAL DIMENSIONS (HxWxD) (mm)		910 x 980 x 1.550

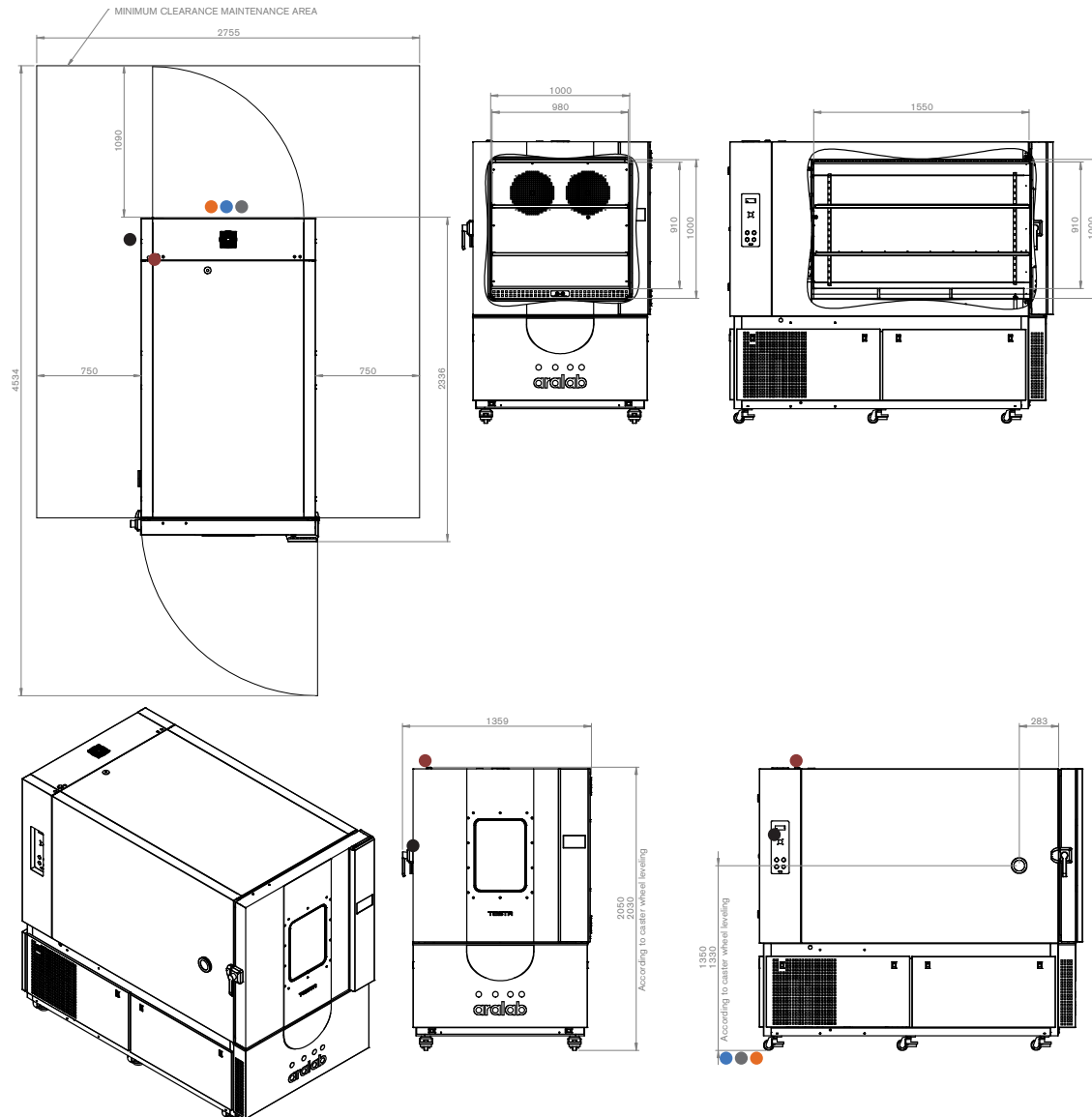

- | | |
|---|---|
| <ol style="list-style-type: none"> 1. Standard refrigeration system is air cooled 2. Services hub installation needs: <ul style="list-style-type: none"> ● 1/2" demineralized water supply Conductivity: <math>< 50 \mu\text{S}/\text{cm}</math> ● 50mm water drain at floor level 3. Electrical cabinet installation needs: <p>Supply power ECP20:
400VAC, 50Hz, 25A / 3-Phase + Neutral + Ground
Electrical protection: Circuit breaker 3 x 25A + N with 300mA differential
Single Phase electrical cable RV K 5G4 on the top</p> <p>Supply power ECP45:
400VAC, 50Hz, 32A / 3-Phase + Neutral + Ground
Electrical protection: Circuit breaker 3 x 32A + N with 300mA differential
3-Phase electrical cable RV-K 5G4 on the top</p> | <ol style="list-style-type: none"> 4. Supply power ECP75:
400VAC, 50Hz, 50A / 3 Phase + Neutral + Ground
Electrical protection: Circuit breaker 3 x 63A + N with 300mA differential
3-Phase electrical cable RV-K 5G10 on the top ● RJ45 communications port ● Water cooled option (is included as standard in -75°C models, 5k and 10k models)
Water flow: up to 2000 l/hr (at 25 °C)
Intake pressure: 2 to 5 bar
Water entry and exit pipe: 1" or 28mm
Differential pressure between entry and exit: $\geq 2,5$ bars
Maximum temperature of water entry: 26 °C
Minimum temperature of water entry: 16 °C
Recommended temperature of water entry: 18 °C |
|---|---|

TESTA CHAMBERS PERFORMANCE	units	Testa TT 1.500 -20	Testa CT 1.500 -20	Testa TT 1.500 -45	Testa CT 1.500 -45	Testa TT 1.500 -75	Testa CT 1.500 -75
PERFORMANCE IN TEMPERATURE TESTING							
Temperature range							
Min	°C	-20	-20	-45	-45	-75	-75
Max	°C	180	180	180	180	180	180
Temperature uniformity (1a) (1b)							
in Space @ low temp. point	°C	± 0,4	± 0,4	± 0,3	± 0,3	± 0,9	± 0,9
in Space @ +25°C	°C	± 0,1	± 0,1	± 0,2	± 0,2	± 0,2	± 0,2
in Space @ high temp point	°C	± 1,3	± 1,3	± 1,5	± 1,5	± 1,5	± 1,5
Max. According to IEC60068-3-5	°C	± 1,5					
Temperature fluctuation in time	°C	± 0,1°C to ± 0,3°C					
Temperature change rate (2a)							
cooling	K/min	2,5	2,5	4	4	3,5	3,5
heating	K/min	3	3	4	4	4,5	4,5
PERFORMANCE IN HUMIDITY TESTING							
Humidity range							
Min	%rH	-	10	-	10	-	10
Max	%rH	-	98	-	98	-	98
Humidity uniformity IEC60068-3-5 (1a) (1b)							
in space	%rH	-	± 2	-	± 2	-	± 2
Fluctuation in time	%rH	-	± 1	-	± 1	-	± 1
DIMENSIONS							
Test space volume	liters	1411					
Shelves							
number of shelves included (more can be added)	#	2					
maximum weight load per shelf	kg	50					
Entry ports							
Included as standard (more can be added)	units	1					
Diameter (other diameters available)	mm	Ø80					
Weight (approximately)	Kg	1100	1175			1220	
POWER & REFRIGERATION							
Supply voltage	V	3/N/PE AC 400V±10% 50Hz-60Hz					
Nominal Power	kW	17	17	22	22	35	35
Type of Refrigeration (air or water cooled)							
Air		Standard				Optional	
Water		Optional				Standard	
Type of Refrigerant		R449A				R449A + R23	
Noise levels	dBA	55 to 64 dBA					

Performances measured in factory with ambient temperatures between 20°C and 25°C.

(1a) Measurements at center of test space, with empty chamber and no optional accessories; (1b) in temperature range up to 150°C;

(2a) According to IEC/EN 60068-3-5. Values will vary with TESTA CT/TESTA TT model, internal volume, compressor type and condenser cooling system. Temperature rate of change can be adjusted to comply with the needed heating / cooling speed requirements. Optional accessories are available for more demanding heating and cooling temperature change rates.

EQUIPMENT DESCRIPTION

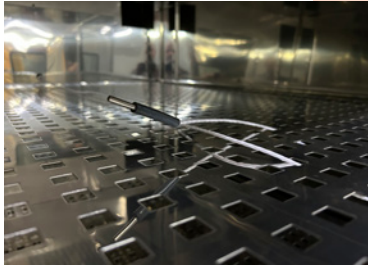

TEMPERATURE

TEMPERATURE SENSORS

- One (1) PT 100 Class A, located in air treatment tunnel
- One (1) PT 100 Class A, movable sensors for flexible placing inside chamber

HEATING

- By stainless steel electric heaters located in the air treatment tunnel

COOLING

- Air cooled hermetic scroll compressor group (low noise and high efficiency) with enforced ventilation and without CFC's. Water-cooled condensers are also available as standard in -75°C models or an option for models with temperature cooling rate upgrades.

THERMAL SECURITY

- Safety thermostat with High / Low temperature configuration, with automatic stop of all thermic systems.
- High / Low temperature alarms programmed in the controller, with mute function. This function will not stop the chamber and it is only used to record the occurrence and to call the attention of the users with an audible alarm.

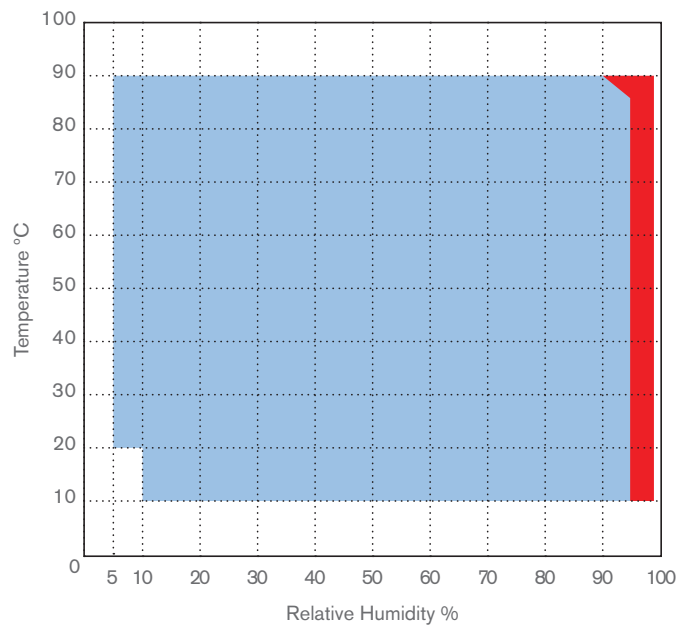

- Standard climatic range
- Non-standard climatic range (psychrometric sensor control)



HUMIDITY (TESTA CT CHAMBERS)

HUMIDITY SENSORS

- To measure and control humidity Aralab uses two different sensor technologies: Psychrometric (EP models), Capacitive (EC models), or both (ECP models). Consult Aralab for technical support on the appropriate selection.

HUMIDITY / DRYING

- Humidity: Through thermostatic bath with dew point control
- Drying: Through thermostatic bath with dew point control and additional dry coil

HUMIDITY SENSORS: HUMIDITY VS. TEMPERATURE RANGES GRAPHIC

- For climatic tests that require humidity and temperature ranges highlighted in red on the graph, a Psychrometric sensor is recommended (EP and ECP models). Please consult Aralab for help on the choice between these two models.



SECURITY

- Automatic stop function in case of water failure, with indication on the controller; High / Low Temperature alarms; High / Low humidity alarms.



CONSTRUCTION

- Interior: AISI 304 hermetical welded, vapour tight, stainless steel
- Exterior: Zinc mild steel with epoxy coating finish (color RAL 7035)
- Insulation: Rock Wool
- Interior illumination: Halogen lamp 12V (only available with optional window)
- Door: Double silicone joints and anti-condensation heating frames (optional window)

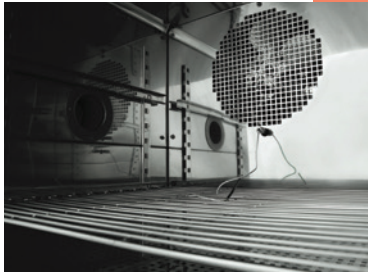

AIR FLOW / VENTILATION

- Air Flow: Forced through 1 or 2 ventilators/fans (300 and 500 models have one ventilator/fan and 1.000 and 1.500 models have two).
- Air Renovation: By lateral port, also for compensating pressure.



CUT-OFF PANEL, SECURITY AND COMMUNICATIONS

On left lateral panel of the chamber and equipped with:

- High / Low safety thermostat
- Mains Power switch
- Audible alarms
- Ethernet communications port



INCLUSIONS

- 2 Stainless steel shelves
- Lockable door
- 1 left side entry port with Ø 80 mm (more can be added)
- 4 or 6 height leveling casters (model dependent)
- Instructions manual
- 2 years' warranty

CLIMAPLUS HMI CONTROLLER

Programmable PLC exclusively developed for ARALAB chambers

Easy to use coloured Touch-Screen Display Interface

Resolution of 0,1°C for Temperature and 0,1% for Relative Humidity

High performance temperature and humidity control with value correction in all ranges

Capability for creating 50 programs of 50 segments each

Internal non volatile memory for storing test data

Automatic restart of tests due to power failure, without losing data and restarting test where it was interrupted

Real-time monitoring of all functions and control of equipment.

Manage control settings via MODBUS/TCP

Possibility of programming a delay of the beginning of test

Monitoring and recording of all alarms

Possibility of performing events by external commands

Several outputs for connecting computers or other devices

Alarms management

Graphic representation of the tests and conditions

Remote access through VNC server

Possibility of running computer test programs and export them to the controller

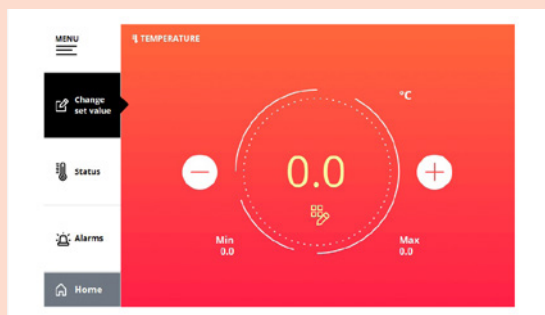
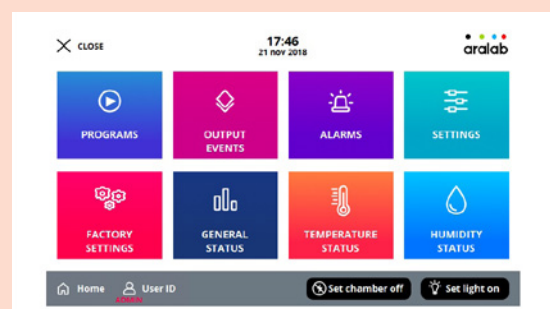

FITOLOG SOFTWARE

The FitoLog software pack is a set of applications designed to facilitate the managing, monitoring and recording of programs and data from the TESTA chambers. It consists of 3 applications: **FitoLog**, **FitoLogView** and **FitoProgram**.



FITOLOG

Records and displays in real time all data and details related to the set-points, running variables and equipment behaviour. It also retrieves information about the active components of the chamber, running processes, errors, alarms and allows the configuration of periodic or alarm triggered remote notifications (by email or SMS, depending on existing connections and accessories).



FITOLOGVIEW

It is a working tool to process the data recorded by the FitoLog program. One can view, print and export the log contents to other file types, and analyse the data in other data management software (Excel, Star Office, Access or others).



FITOPROGRAM

This application simplifies the creation of programs and its integration on the chamber ClimaPlus controller. Up to 32 programs, each with 24 segments, can be designed and linked to create detailed environmental profiles and simulations.

NOTIFICATIONS, FAST DIAGNOSTICS AND PROMPT TROUBLESHOOTING

With FitoLog it is possible to gather data from each of the chambers systems, which makes it a very useful tool to diagnose any necessary maintenance. This tool works as the "black box" of the equipment, giving Aralab technicians the necessary data to remotely carry out a fast and efficient diagnostic. All that is needed is a FitoLog file.

ACCESSORIES AND APPLICATIONS



Door with observation window



Compressed Air Dryer



Additional Entry-ports



Cold Bend Cables Testing

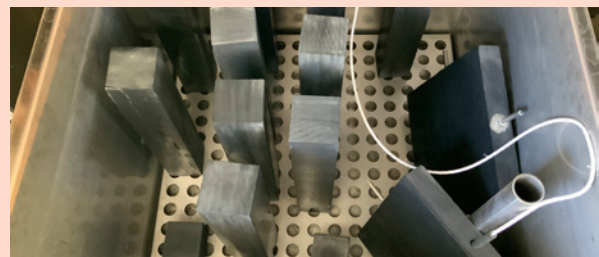

Freeze-Thaw test tank



Electronic safety locks



Gas Sensors



EUCAR Battery testing



Solar and UV radiation simulation



Safety stack light signal



Water supply tank

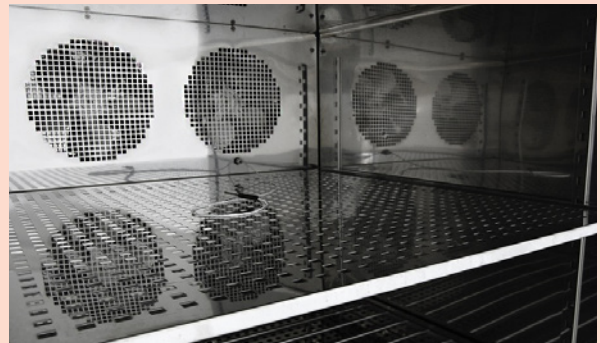

Reinforced Shelves (up to 100 Kg load)



Sprinkler - Rain simulation



Shaker Integrations for vibration testing



Latex gloves ports



Water Treatment systems

INSTALLATION REQUIREMENTS

INSTALLATION SITE

The place should be easily accessible, according to equipment dimensions and weight. It should have good air circulation and a room temperature between 10° and 26°C. The floor should be leveled and a minimum distance of 50cm from the walls and other equipment must be kept.

ELECTRICAL SUPPLY

Near the equipment with the specified requirements.

HUMIDIFICATION CIRCUIT AND DEMINERALIZED WATER (FOR TESTA CT MODELS)

The humidification circuit works exclusively with distilled or demineralized water. For this circuit, a water admission pressure of 1 to 6 bares and conductivity of $\leq 50\mu$ Siemens is required.

WATER CIRCUIT FOR COOLING CONDENSER

(Standard and required for in -75C models and versions with Temperature cooling rate upgrade; Optional for -25 and -45C models)

A cold water circuit is required for the cold system condenser. Technical characteristics:

- Water flow: up to 2000 liters/hour (at 25°C)
- Intake pressure: 2 to 5 bar
- Water entry and exit pipe: 1" or 28mm
- Differential pressure between entry and exit: $> 0,5$ bars
- Maximum temperature of water entry: 26°C
- Minimum temperature of water entry: 16°C
- Recommended temperature of water entry: 18°C

DRAIN

At floor level and near the equipment. The draining of the humidification and cooling systems water is done by gravity. For a correct draining there should be a minimum inclination of 10° in a descending trajectory from the chambers draining pipe until the sewage system.

Features and specifications are subject to change. Aralab continuously studies ways to further develop its products to achieve better performances and overall product quality. As a result, characteristics and specifications provided in this document may be subject to changes.

Let's meet!
aralab@aralab.pt
www.aralab.pt
T: +351 219 154 960



[f/AralabChambers](#)
[in/company/aralab](#)
[v/user/AralabChambers](#)
[t/Aralab_](#)
[@aralabchambers](#)



Control the environment
Your own climate