

# User instructions

## Stereo zoom microscope

**KERN**

**OZO-5, OZP-5**

OZO 551, OZO 552, OZO 553, OZO 554  
OZP 555, OZP 556, OZP 557, OZP 558

Version 1.0  
01/2015







---

---

# KERN OZO-5, OZP-5

Version 1.0 01/2015

## User instructions

### Stereo zoom microscope

---

---

## Table of contents

<b>1</b>	<b>Before use .....</b>	<b>3</b>
1.1	General notes.....	3
1.2	Notes on the electrical system.....	3
1.3	Storage .....	4
1.4	Maintenance and cleaning.....	5
<b>2</b>	<b>Nomenclature .....</b>	<b>6</b>
<b>3</b>	<b>Basic data.....</b>	<b>8</b>
<b>4</b>	<b>Assembly .....</b>	<b>9</b>
<b>5</b>	<b>Operation and functionality.....</b>	<b>11</b>
5.1	Getting started .....	11
5.2	Adjust the interpupillary distance .....	11
5.3	Adjusting the magnification .....	11
5.4	Dioptre adjustment and focussing .....	12
5.5	Adjusting the stand .....	13
5.6	Using eye cups / High Eye Point eyepieces .....	14
5.7	Brightness adjustment.....	15
5.8	Using external illumination units.....	16
5.9	Fitting and adjusting a camera .....	17
5.10	Using additional accessories .....	19
5.11	Changing the bulb .....	21
5.12	Changing the fuse .....	21
<b>6</b>	<b>Optical data .....</b>	<b>22</b>
<b>7</b>	<b>Features.....</b>	<b>23</b>
<b>8</b>	<b>Trouble shooting.....</b>	<b>25</b>
<b>9</b>	<b>Service .....</b>	<b>26</b>
<b>10</b>	<b>Disposal.....</b>	<b>26</b>
<b>11</b>	<b>Further information.....</b>	<b>26</b>

# **1 Before use**

## **1.1 General notes**

You must open the packaging carefully, to make sure that none of the accessories in the packaging fall on the floor and get broken.

In general, microscopes should always be handled carefully because they are sensitive precision instruments. When using or transporting the microscope it is particularly important to avoid abrupt movements, as this may damage the optical components.

You should also avoid getting dirt or finger prints on the lens surface, because in most cases this will reduce image clarity.

To maintain the performance of the microscope, it must never be disassembled. So components such as lenses and other optical elements should be left as they were before use. Also the electrical parts in the base of the device must not be tampered with, as in this area there is an additional risk of triggering an electric shock.

## **1.2 Notes on the electrical system**

**(OZO 552, OZO 554, OZP 556, OZP 558)**

Before connecting to a mains power supply, you must make sure that you are using the correct input voltage. The information to select the correct mains cable is located on each device, on the rear of the product directly above the connection socket. You must comply with this information. If you do not comply with these specifications, then fires or other damage to the device could occur.

The main switch must also be switched off before the mains cable is connected. In this way you will avoid triggering an electric shock.

If you are using an extension cable, then the mains cable you use must be earthed.

If the original fuse should blow, it must only be replaced by an appropriate fuse. Suitable replacement fuses are included with the delivery.

When carrying out any procedures whereby you come into contact with the electrical system of the device, such as, for example, changing the bulb or fuse, only carry out these procedures when the power is disconnected.

### 1.3 Storage

You should ensure that the device is not exposed to direct sunlight, temperatures which are too high or too low, vibrations, dust or a high level of humidity.

The ideal temperature range is between 0 and 40°C and a relative humidity of 85% should not be exceeded.

The device should always be located on a rigid, smooth, horizontal surface.

For devices with pillar stands, the microscope holder must not be rotated back too far. If you do this, there is a risk that the microscope could tip over.

When the microscope is not being used, you should fit the objective cap and cover the microscope with the enclosed dust protective cover.

If the eyepieces are being stored separately, the protective caps must be fitted to the tube connectors. In most cases, if dust and dirt gets inside the optical unit of a microscope this can cause irreversible errors or damage.

The best way to store accessories which consist of optical elements, such as, for example, eyepieces and objectives, is in a dry box with desiccant.

## 1.4 Maintenance and cleaning

In any event, the device must be kept clean and dusted regularly.

If any moisture should occur, before you wipe down the device you must ensure that the mains power is switched off (if lighting unit is fitted).

When glass components become dirty, the best way to clean them is to wipe them gently with a lint-free cloth.

To wipe oil stains or finger prints off the lens surface, moisten the lint free cloth with a mixture of ether and alcohol (70 / 30 ratio) and use this to clean the lens.

You must be careful when handling ether and alcohol, as these are highly flammable substances. You must therefore keep it away from naked flames and electrical devices which can be switched on and off, and only use it in well-ventilated rooms.

However organic solutions of this type should not be used to clean other components of the device. This could lead to damage to the paint finish. To do this, it is sufficient to use a neutral cleaning product.

You could also use the following cleaning products to clean the optical components:

- Special cleaner for optical lenses
- Special optical cleaning cloths
- Bellows
- Brush

When handled correctly and checked regularly, the microscope should give many years of efficient service.

Should repairs still be necessary, please contact your KERN dealer or our Technical Department.

## 2 Nomenclature

Using the OZP 558 as an example  
(Trinocular / with lighting)

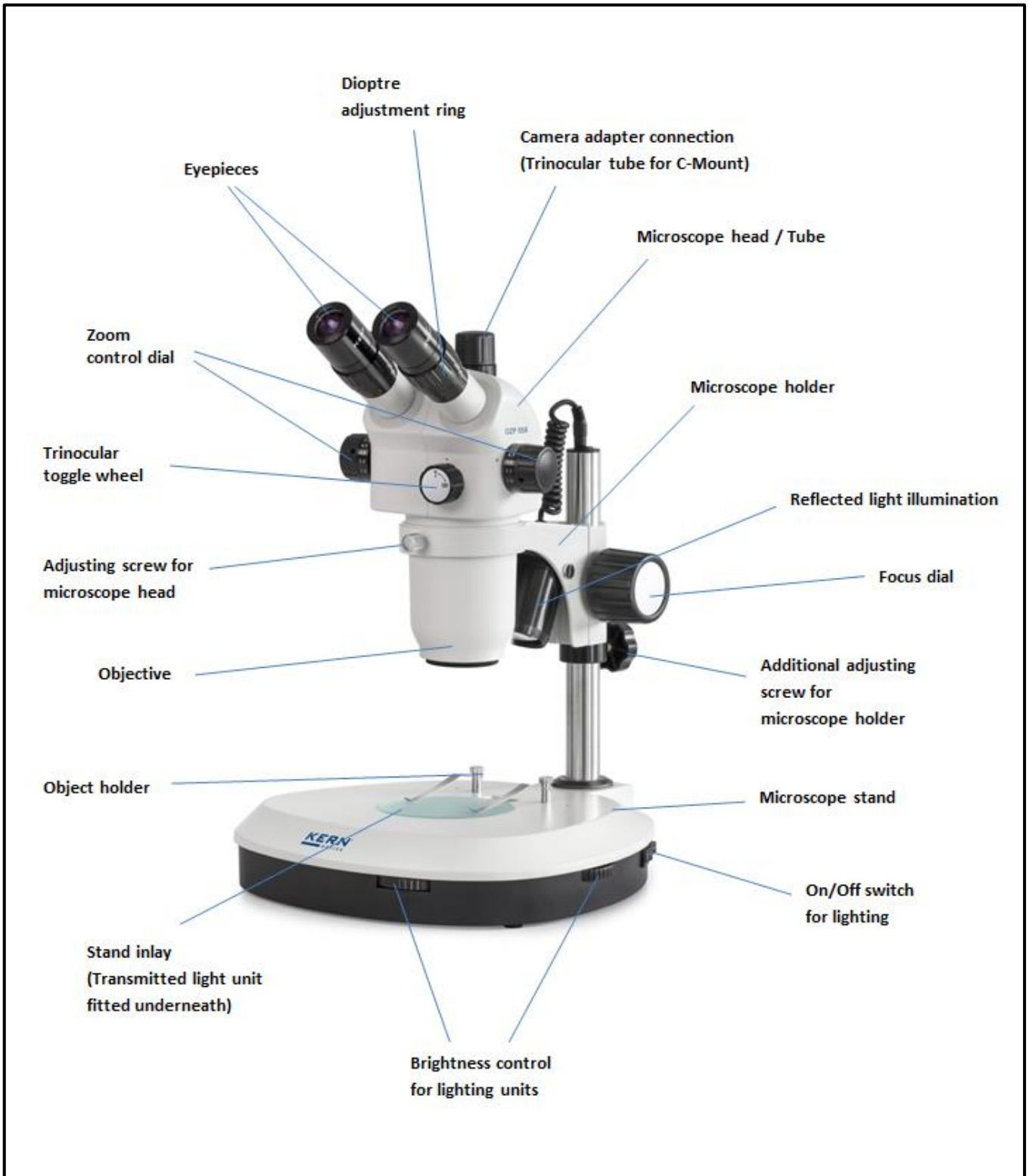

**Rear view**

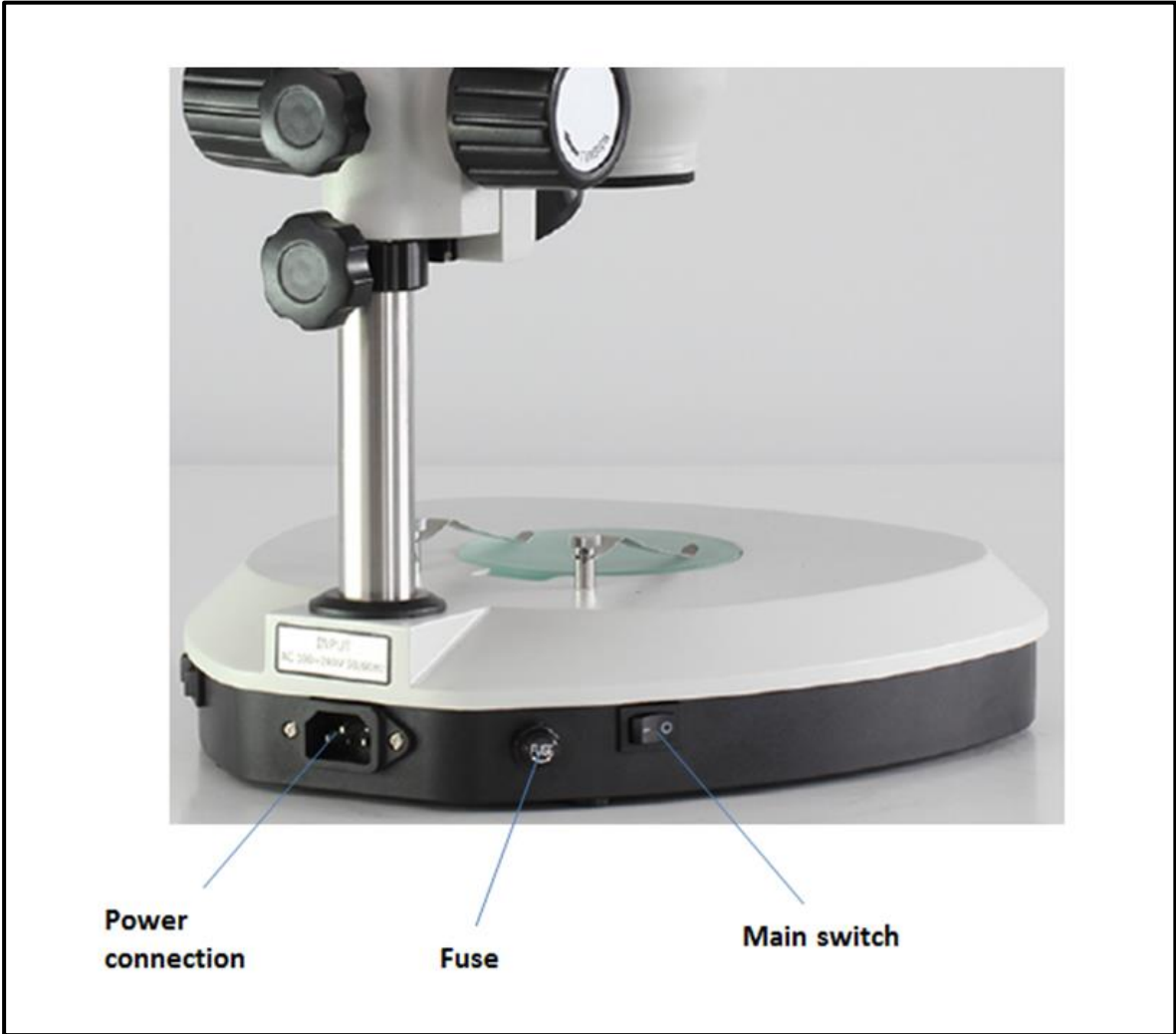



### 3 Basic data

#### OZO-5 / OZP-5

Optical system	Greenough
Dimmable lighting	Yes
Tube	angled at 35°
Interpupillary distance	52 – 76 mm
Dioptre adjustment	On both sides
Packaging dimensions WxDxH	370 x 330 x 385 mm

#### OZO-5

Magnification ratio	8.8:1
---------------------	-------

#### OZP-5

Magnification ratio	9.2:1
---------------------	-------

#### Standard configuration

Model	Tube	Eyepiece	Field of view	Objective	Stand	illumination
KERN			mm	Zoom		
OZO 551	Binocular	HSWF 10x Ø 23 mm	Ø 28.75 – 3.3	0.8x – 7x	Pillar	-
OZO 552	Binocular	HSWF 10x Ø 23 mm	Ø 28.75 – 3.3	0.8x – 7x	Pillar	3W LED (reflected light); 3W LED (transmitted light)
OZO 553	Trinocular	HSWF 10x Ø 23 mm	Ø 28.75 – 3.3	0.8x – 7x	Pillar	-
OZO 554	Trinocular	HSWF 10x Ø 23 mm	Ø 28.75 – 3.3	0.8x – 7x	Pillar	3W LED (reflected light); 3W LED (transmitted light)
OZP 555	Binocular	HSWF 10x Ø 23 mm	Ø 38.3 – 4.2	0.6x -5.5x	Pillar	-
OZP 556	Binocular	HSWF 10x Ø 23 mm	Ø 38.3 – 4.2	0.6x -5.5x	Pillar	3W LED (reflected light); 3W LED (transmitted light)
OZP 557	Trinocular	HSWF 10x Ø 23 mm	Ø 38.3 – 4.2	0.6x -5.5x	Pillar	-
OZP 558	Trinocular	HSWF 10x Ø 23 mm	Ø 38.3 – 4.2	0.6x -5.5x	Pillar	3W LED (reflected light); 3W LED (transmitted light)

## 4 Assembly

The first step is to position the **microscope stand on a firm, level surface**. The term stand covers the stand base (standing surface) as well as the metal pillar which is connected to it.

**The holder** is already on pillar of the stand, but you must always check whether it is **fixed** securely and that it is in the **correct position** (preferably centrally and facing to the front).

*Please see section 5.5 for more details on adjusting the stand.*

The next step is to place the **microscope head on the holder**, by passing the objective through the holder ring until the rest of the head is above the ring.

You must use the small silver adjusting screw on the front of the holder ring to **fix the head** in place.

The alignment of the microscope head is left to the user to do and can be adjusted to suit the individual application situations.

To make it easier to operate the focus wheels or lighting control for example, we recommend that you position the head with the tube connectors centrally to the front. Ideally, the holder and head are then parallel on the central axis of the stand base (*see figure on page 10*).

Then you can remove the protective caps from the tube connectors so that you can then **fit the eyepieces**. When doing this, please be particularly careful that you do **not touch the optical lenses with your fingers** and that no dust enters the apertures.

You should also **never fit two eyepieces with different magnifications**.

With regard to the use of a device **with lighting** (OZO 552, OZO 554, OZP 556, OZP 558) you must make sure that the **frosted glass stand inlay is fitted in the centre of the stand base**, so that the transmitted light can be used correctly.

Also, when using reflected light please make sure, that the **connection cable between the holder and upper side of the pillar is plugged in**.

### **Additional optional attachments:**

- The eye cups supplied with the microscopes can be fitted to the eyepieces. (*see section 5.6*).
- You can fit a C-mount adapter to the appropriate connection point on the top of the microscope head for trinocular devices (OZO 553, OZO 554, OZP 557, OZP 558). This enables you to fit and use digital cameras. (remove protective cap first) (*see section 5.9*).



Assembled stereo zoom microscope

## 5 Operation and functionality

### 5.1 Getting started

After assembly, if the microscope is ready for use, then for devices with lighting (OZO 552, OZO 554, OZP 556, OZP 558) you must first establish a **power connection** using the cable supplied.

*Please see section 5.7 for more details on adjusting the lighting.*

If the device has a camera connection (OZO 553, OZO 554, OZP 557, OZP 558), then for **binocular** use, you must first set the **trinocular toggle wheel** on the front of the microscope head to “**B**”.

*For trinocular use (camera connection) see section 5.9.*

Do not forget to remove the cap from the bottom of the objective, so that you will then be able to see a reflection of the object being observed in the eyepiece.

All important functions which relate to the use of the devices in this document are described in the following sections.

### 5.2 Adjust the interpupillary distance

Different users have different interpupillary distances. So each time a different person uses the microscope, the gap between the two eyepieces must be re-adjusted.

While you are looking through the eyepieces, use one hand to hold the righthand or lefthand tube connector firmly.

By pulling them apart or pushing them together, you can either increase or reduce the interpupillary distance.

As soon as the lefthand and righthand visual fields exactly overlap each other, this is the correct interpupillary distance.

### 5.3 Adjusting the magnification

As the KERN OZO-5 and OZP-5 series are stereo zoom microscopes, then you adjust the magnification using the two zoom adjustment wheels on the lefthand and righthand side of the microscope head.

*Chapter 6 “Optical data” gives information on the possible overall magnification which the microscope can produce. It will also include the optional use of different eyepieces and auxiliary objectives.*

## 5.4 Dioptre adjustment and focussing

A special feature of stereo microscopes is that they are fitted with an optical unit which has a relatively high depth of field. In order to be able get the most benefit from this feature, each user must synchronise the focussing mechanisms for themselves.

The steps to do this are described in the following section.

1. Place the object to be observed on the working surface under the objective.
2. Put both dioptre adjustment rings into the starting position of 0.
3. Use the zoom control dials to set the smallest possible magnification.
4. Look through the right eyepiece with the right eye and bring the object into focus by using the focus control dials.
5. Now set the largest possible zoom factor.
6. Once again, still only looking through the right eyepiece, bring the object into focus
7. Then set the smallest possible zoom factor again.
8. If the object then does not appear to be in focus, adjust the focus on the dioptre adjustment ring of the right eyepiece.
9. In order to get the highest level of accuracy when adjusting the focus, you should repeat steps 5-8.
10. Afterwards set back to the smallest possible zoom factor.
11. Then look through the left eyepiece with the left eye and use the lefthand dioptre adjustment ring to also adjust the optimum focus of the object.
12. In this way, the object being observed will be in focus at any zoom setting.

## 5.5 Adjusting the stand

### Torque of the focus wheels

You adjust the torque of the focus wheels by holding one of the two wheels in place and using the other hand to turn the other wheel.

Depending on the direction of the turn, the torque will be increased or decreased.

On one hand, this function can help to make it easier to adjust the focus and on the other hand it can prevent the microscope head from slipping down unintentionally. In this way you can avoid possible damage which could occur if the objective lens and the object being observed should collide.

### Height adjustment

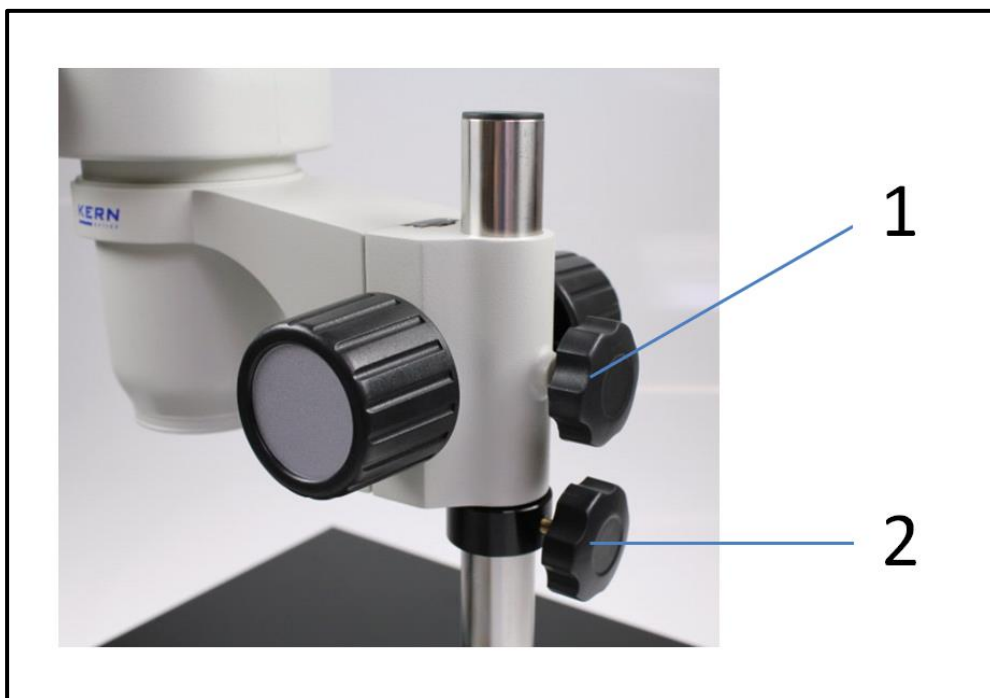

#### Fixing the microscope holder

With a stereo microscope on a pillar stand, the microscope head can be height adjusted using the focus wheels and in addition, the microscope holder can be fixed at any point on the pillar, depending on the application requirements.

To primary way to fix the position is to use an adjusting screw (1) on the holder.

There is a metal ring which also ensures sufficient grip and which is fixed with a second screw (2) under the holder on the pillar. This metal ring proves to be particularly useful when the screw (1) on the holder is loosened, to swing the microscope head to the side.

## 5.6 Using eye cups / High Eye Point eyepieces

The eye cups supplied with the microscope can basically be used at all times, as they screen out intrusive light, which is reflected from light sources from the environment onto the eyepiece, and the result is better image quality.

But primarily, if eyepieces with a high eye point (particularly suitable for those who wear glasses) are used, then it may also be useful for users who don't wear glasses, to fit the eye cups to the eyepieces.

These special eyepieces are also called High Eye Point eyepieces. They can be identified by the glasses symbol on the side. They are also marked in the item description by an additional "H" (example: HSWF 10x Ø 23 mm).

When fitting the eye cups, make sure that the dioptre setting is not moved. We would therefore advise that you hold the dioptre adjustment ring on an eyepiece with one hand while you fit the eye cup with the other.

Before using the microscope, users who wear glasses must remove the eye cups, which you may find on High Eye Point eyepieces.

As the eye cups are made of rubber, you must be aware that when you are using them, they can become slightly dirty through grease residues. In order to maintain hygiene, we would therefore recommend that you clean the eye cups regularly (e.g. with a damp cloth).



Eye cups



High Eye Point eyepiece  
(identified by the glasses symbol)

## 5.7 Brightness adjustment

(OZO 552, OZO 554, OZP 556, OZP 558)

For microscopes which have integrated lighting, the necessary on/off switches are on the righthand side of the stand base on/off switch (see figure).

Provided that the main switch is switched on, you can operate the reflected light and transmitted light using these two switches. Looking at the microscope from the righthand side, the lefthand switch (3) is for transmitted light and the righthand switch (4) is for reflected light.

You can also adjust the light intensity for both lighting units. To do this there are two wheels on the stand base. The wheel at the front (1) is for adjusting the brightness of the transmitted light and the wheel on the righthand side (2), next to the switches, is for adjusting the brightness of the reflected light. Depending on which way you turn the wheel, the corresponding light will become lighter or darker.

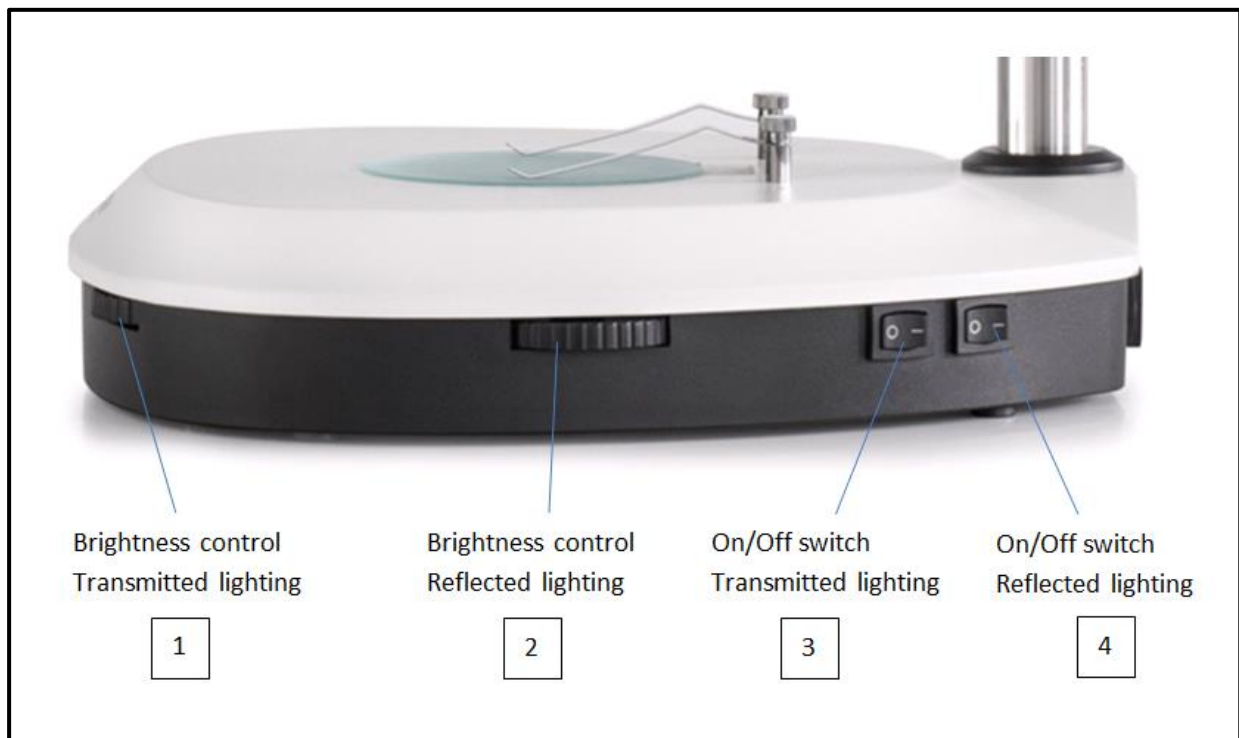

Control elements for the lighting unit



## 5.8 Using external illumination units

If, when using a microscope in its standard version, the lighting is not suitable for the application, then it often makes sense to fit an external lighting unit to overcome this problem.

These lighting units are divided into two groups.

- Ring lighting units (*left figure*), usually LED
- Goose neck lighting units (*right figure*), both Halogen and LED as standard

Both units require an extra power connection and can, depending on the model, also have an on/off switch and various lighting unit controls.



Typical ring lighting unit



Typical goose neck lighting unit

### Fitting a ring lighting unit

As you can see in the figure on the left, the ring lighting units have three screws which must be positioned such that they do not protrude into the ring. The ring will be fitted round the objective and the screws will be screwed in until the lighting unit is fixed firmly onto the objective.

### Using goose neck lighting units

Depending on the requirements, a goose neck lighting unit is placed next to, in front of or behind the microscope. The light source is in the housing of the unit and is emitted through one or several optical fibre cables.

These cables are flexible and therefore offer a large number of positioning options, so that the object being observed is perfectly illuminated.

## 5.9 Fitting and adjusting a camera (OZO 553, OZO 554, OZP 557, OZP 558)



You can connect special microscope cameras and reflex cameras to trinocular devices in the OZO-5 and OZP-5 series, so that you can digitally record images or sequences of objects being observed.

**The connection for this is on the top side of the microscope head** (see figure above).

When the **trinocular toggle wheel is set to "T"**, the beam path, which normally emits on the righthand eyepiece, is diverted in the tube, so that it can be used for the camera adapter connection.

This means that when the device is used in trinocular mode, you will see one image in the left eyepiece and one on the reflex camera or monitor of the microscope camera.

This means that the 3D effect is lost.

**To fit a microscope camera properly, you must use an adapter with a C-mount thread, which is put in the adapter connection once the cap is removed.**

In total there are three focusable adapters to choose from (*see figure below*). The difference between these adapters is that they have different integrated magnification (0.3x, 0.5x, 1.0x).

**The camera and adapter are then united using the C-mount thread.**

For special measuring applications in conjunction with a microscope camera, when using the 1.0x C-mount, there is the option of screwing in a second adapter with an integrated micrometre in front of the camera.



C-mount adapter

**You also need an adapter to connect a reflex camera. But in contrast to the microscope camera this does not have a C-mount thread, but has a bayonet connection which fits directly on the camera objective.**

There are also three different adapters to choose from. They all have a 1x magnification and differ in the fact that they come from different camera manufacturers. **Canon, Nikon and Olympus** cameras can be used for this.

The image which is shown on the camera connected to the device can often have a different level of focus compared with the image on the eyepiece, when **adapters with integrated magnification (0,3x, 0,5x)** are used. In order to be able to bring both images into focus, **the focus can be adjusted by those adapters.**

## 5.10 Using additional accessories

### Auxiliary objectives



In order to make the magnification series of one of the stereo zoom microscopes described here even more flexible, there is the option of using appropriate auxiliary objectives.

As you can see in Chapter 7 “Features”, you can choose from five different achromatic corrected objectives (0.37x, 0.5x, 0.7x, 1.5x, 2.0x), depending on what is required.

You can fit these objectives by simply screwing them onto the bottom side of the microscope head.

When you are doing this, you must avoid touching the objective lenses with your fingers or leaving any dust between the standard objective and the auxiliary objective.

### Dark field kit and object clamp

Microscopes from the OZO-5 and OZP-5 series are ideal for dark field applications. Dark field attachments and object clamps are available as accessories for these applications.

You just have to fit the dark field attachment in the recess in the middle of the stand base. You must first remove the stand inlay which is fitted.

The object clamp which you need for dark field applications can be fitted using its thread (see *left figure*) on one of the two sockets, next to the object holder on the stand base (see *right figure*).



## Angle table



Standard angle table



Angle table for using transmitted light

For easier handling of an object to be observed, it can be useful to fit an additional mechanical angle table on the working surface of a stereo microscope.

For devices without lighting you can use a standard angle table (*see left figure*). However if there is an integrated transmitted lighting unit, you should use a special angle table with transmitted light compatibility (*see right figure*).

As the figures show, both versions each have two coaxially positioned adjustment wheels in the righthand rear corner of the table. This means that you can move it in the x and y directions.

To fit this, the user must bore four holes through the surface of the stand base at particular points on the edge of the recess for the stand inlay. Then the screws included with the table can be used to fix the table from the underside.

A user guide is included with the delivery of each angle table which contains the precise instructions on how to fit it. We strongly recommend that you follow these instructions closely, to make sure that you will be able to use the angle table without problems.

## 5.11 Changing the bulb

### LED

Devices from the OZO-5 and OZP-5 series with lighting units are all fitted with LED bulbs.

Due to the long service life of an LED lighting system, for these microscopes it will not be necessary to simply change a bulb.

Problems with the lighting unit would therefore, in most cases, be caused by defects in the electrical system. If this is the case, then our Technical Service will be able to help.

## 5.12 Changing the fuse

The fuse is on the rear of microscope stand base next to the main switch (*label: "Fuse"*).

If the fuse has blown, then with the device switched off and the power disconnected, the fuse can easily be screwed out and replaced with a new one.

## 6 Optical data

### OZO-5

Eyepiece	Specifications - Objectives						
	Magnification	Standard 1,0x	Auxiliary objectives				
			0,37x	0,5x	0,7x	1,5x	2x
HSWF 10x	Total magnification	8x - 70x	2,96x - 25,9x	4x - 35x	5,6x - 49x	12x - 105x	16x - 140x
	Field of view mm	Ø 28,75 - 3,3	Ø 74,3 - 8,5	Ø 57,5 - 6,6	Ø 41,1 - 4,7	Ø 19,2 - 2,2	Ø 14,4 - 1,6
SWF 15x	Total magnification	12x - 105x	4,44x - 38,9x	6x - 52,5x	8,4x - 73,5x	18x - 157,5x	24x - 210x
	Field of view mm	Ø 21,25 - 2,4	Ø 57,4 - 6,6	Ø 42,5 - 4,9	Ø 30,4 - 3,5	Ø 14,2 - 1,6	Ø 10,6 - 1,2
SWF 20x	Total magnification	16x - 140x	5,92x - 51,8x	8x - 70x	11,2x - 98x	24x - 210x	32x - 280x
	Field of view mm	Ø 17,5 - 2	Ø 47,3 - 5,4	Ø 35 - 4	Ø 25 - 2,9	Ø 11,7 - 1,3	Ø 8,75 - 1
SWF 30x	Total magnification	24x - 210x	8,88x - 77,7x	12x - 105x	16,8x - 147x	36x - 315x	48x - 420x
	Field of view mm	Ø 11,25 - 1,3	Ø 30,4 - 3,5	Ø 22,5 - 2,6	Ø 16,1 - 1,8	Ø 7,5 - 0,9	Ø 5,625 - 0,6
Working distance		108 mm	275 mm	195 mm	145 mm	50 mm	35 mm

### OZP-5

Eyepiece	Specifications - Objectives						
	Magnification	Standard 1,0x	Auxiliary objectives				
			0,37x	0,5x	0,7x	1,5x	2x
HSWF 10x	Total magnification	6x - 55x	2,22x - 20,4x	3x - 27,5x	4,2x - 38,5x	9x - 82,5x	12x - 110x
	Field of view mm	Ø 38,3 - 4,2	Ø 99,1 - 10,8	Ø 76,7 - 8,4	Ø 54,8 - 6	Ø 25,6 - 2,8	Ø 19,2 - 2,1
SWF 15x	Total magnification	9x - 82,5x	3,33x - 30,5x	4,5x - 41,25x	6,3x - 57,75x	13,5x - 123,75x	18x - 165x
	Field of view mm	Ø 28,3 - 3,1	Ø 76,6 - 8,35	Ø 56,7 - 6,2	Ø 40,5 - 4,4	Ø 18,9 - 2,1	Ø 14,2 - 1,5
SWF 20x	Total magnification	12x - 110x	4,44x - 40,7x	6x - 55x	8,4x - 77x	18x - 165x	24x - 220x
	Field of view mm	Ø 23,3 - 2,5	Ø 63,1 - 6,9	Ø 46,7 - 5,1	Ø 33,3 - 3,6	Ø 15,6 - 1,7	Ø 11,7 - 1,3
SWF 30x	Total magnification	18x - 165x	6,66x - 61,1x	9x - 82,5x	12,6x - 115,5x	27x - 247,5x	36x - 330x
	Field of view mm	Ø 15 - 1,6	Ø 40,5 - 4,4	Ø 30 - 3,3	Ø 21,4 - 2,3	Ø 10 - 1,1	Ø 7,5 - 0,8
Working distance		108 mm	275 mm	195 mm	145 mm	50 mm	35 mm

## 7 Features

### OZO-5

Model outfit		Kern model				Order number
		OZO 551	OZO 552	OZO 553	OZO 554	
Eyepieces	HSWF 10x / Ø 23 mm	●●	●●	●●	●●	OZB-A5503
	SWF 15x / Ø 17 mm	○○	○○	○○	○○	OZB-A5504
	SWF 20x / Ø 14 mm	○○	○○	○○	○○	OZB-A5505
	SWF 30x / Ø 9mm	○○	○○	○○	○○	OZB-A5506
	HSWF 10x / Ø 23 mm (with 0.1 mm scale)	○	○	○	○	OZB-A5512
	SWF 15x / Ø 17 mm (with 0.05 mm scale)	○	○	○	○	OZB-A5513
	SWF 20x / Ø 14 mm (with 0.05 mm scale)	○	○	○	○	OZB-A5514
Achromatic Auxiliary objectives	0.37x	○	○	○	○	OZB-A5611
	0.5x	○	○	○	○	OZB-A5612
	0.7x	○	○	○	○	OZB-A5613
	1.5x	○	○	○	○	OZB-A5615
	2.0x	○	○	○	○	OZB-A5616
C-mount	0.3x			○	○	OZB-A5701
	0.5x			○	○	OZB-A5702
	1.0x			○	○	OZB-A5703
	1.0x (with micrometre)			○	○	OZB-A5704
	for SLR cameras (Nikon)			○	○	OZB-A5706
	for SLR cameras (Olympus)			○	○	OZB-A5707
	for SLR cameras (Canon)			○	○	OZB-A5708
Dark field attachment	○	○	○	○	OBB-A6201	
Object clamp	○	○	○	○	OBB-A6205	
Stand	Pillar, without lighting	●		●		
	Pillar, with 3W LED lighting (Transmitted light and reflected light)		●		●	
	For further stands, please see the Kern Optics main catalogue, from page 64 and please visit our website <a href="http://www.kern-sohn.com">www.kern-sohn.com</a>					
Stand inlay	Frosted glass – Ø94.5 mm		●		●	OZB-A5192
	Black/White – Ø94.5 mm	●	●	●	●	OZB-A5191
	Glass – Ø94.5 mm		○		○	OZB-A5190
Table mechanical	Dimensions WxD 188 x 160 mm, Travel: 76x65mm, for reflected light and transmitted light	○	○	○	○	OZB-A5781
	Dimensions WxD 180 x 175 mm, Travel: 100x86mm, for reflected light	○	○	○	○	OZB-A5782
External illumination	For information on external lighting units, please see the Kern Optics main catalogue, from page 68 and visit our website <a href="http://www.kern-sohn.com">www.kern-sohn.com</a>					

● = Standard configuration

○ = Option



## OZP-5

Model outfit		Kern model				Order number
		OZP 555	OZP 556	OZP 557	OZP 558	
Eyepieces	HSWF 10x / Ø 23 mm	●●	●●	●●	●●	OZB-A5503
	SWF 15x / Ø 17 mm	○○	○○	○○	○○	OZB-A5504
	SWF 20x / Ø 14 mm	○○	○○	○○	○○	OZB-A5505
	SWF 30x / Ø 9mm	○○	○○	○○	○○	OZB-A5506
	HSWF 10x / Ø 23 mm (with 0.1 mm scale)	○	○	○	○	OZB-A5512
	SWF 15x / Ø 17 mm (with 0.05 mm scale)	○	○	○	○	OZB-A5513
	SWF 20x / Ø 14 mm (with 0.05 mm scale)	○	○	○	○	OZB-A5514
Achromatic Auxiliary objectives	0.37x	○	○	○	○	OZB-A5611
	0.5x	○	○	○	○	OZB-A5612
	0.7x	○	○	○	○	OZB-A5613
	1.5x	○	○	○	○	OZB-A5615
	2.0x	○	○	○	○	OZB-A5616
C-mount	0.3x			○	○	OZB-A5701
	0.5x			○	○	OZB-A5702
	1.0x			○	○	OZB-A5703
	1.0x (with micrometre)			○	○	OZB-A5704
	for SLR cameras (Nikon)			○	○	OZB-A5706
	for SLR cameras (Olympus)			○	○	OZB-A5707
	for SLR cameras (Canon)			○	○	OZB-A5708
Dark field attachment	○	○	○	○	OBB-A6201	
Object clamp	○	○	○	○	OBB-A6205	
Stand	Pillar, without lighting	●		●		
	Pillar, with 3W LED lighting (Transmitted light and reflected light)		●		●	
	For further stands, please see the Kern Optics main catalogue, from page 64 and please visit our website <a href="http://www.kern-sohn.com">www.kern-sohn.com</a>					
Stand inlay	Frosted glass – Ø94.5 mm		●		●	OZB-A5192
	Black/White – Ø94.5 mm	●	●	●	●	OZB-A5191
	Glass – Ø94.5 mm		○		○	OZB-A5190
Table mechanical	Dimensions WxD 188 x 160 mm, Travel: 76x65mm, for reflected light and transmitted light	○	○	○	○	OZB-A5781
	Dimensions WxD 180 x 175 mm, Travel: 100x86mm, for reflected light	○	○	○	○	OZB-A5782
External illumination	For information on external lighting units, please see the Kern Optics main catalogue, from page 68 and visit our website <a href="http://www.kern-sohn.com">www.kern-sohn.com</a>					

● = Standard configuration

○ = Option

## 8 Trouble shooting

### Electrical system

Problem	Possible causes
The lighting unit (if fitted) cannot be switched on	The power cable is either not connected or not connected correctly
	The bulb is not fitted
	The bulb has blown
	The fuse has blown
The bulb has blown	The brightness control is set to the lowest level
	The wrong bulb has been used
The bulb flickers	The input voltage was too high
	The bulb is not correctly fitted
The bulb brightness is not sufficient	The lamp is worn out
	The wrong bulb has been used
	The input voltage is too low

### Optical unit

Problem	Possible causes
You can see two images	The interpupillary distance is not set correctly
	The magnifications of the eyepieces do not match
There is dirt in the visual field	There is dirt on the object being observed
	There is dirt on the eyepiece surface
The image is unclear	There is dirt on the objective surface
The focus wheels are jammed	The torque of the focus wheels is set too high
The microscope head slips down while you are viewing the object	The torque of the focus wheels is set too low
Eyes get tired easily	The dioptre adjustment is not correct
	The brightness adjustment is not correct

## 9 Service

If, after studying the user manual, you still have questions about commissioning or using the microscope, or if unforeseen problems should arise, please get in touch with your dealer. The device may only be opened by trained service engineers who have been authorised by KERN.

## 10 Disposal

The packaging is made of environmentally-friendly materials, which you can dispose of at your local recycling centre. Disposal of the storage box and device must be carried out by the operator in accordance with all national or regional laws in force in the location of use.

## 11 Further information

The illustrations may differ slightly from the product.

The descriptions and illustrations in this user manual are **subject to change without notice**. Further developments on the device may lead to these changes.



All language versions contain a non-binding translation.  
The original German document is the binding version.

# User Instructions

## Tablet camera

for microscopes

**KERN**

**ODC-2**

ODC 241

Version 1.1  
09/2022







# **KERN ODC-2**

Version 1.0 01/2019

## **User Instructions**

### **Tablet camera for microscopes**

---

---

## **Table of contents**

<b>1</b>	<b>Before use .....</b>	<b>3</b>
1.1	General notes.....	3
1.2	Storage .....	3
<b>2</b>	<b>Scope of supply .....</b>	<b>4</b>
<b>3</b>	<b>Nomenclature .....</b>	<b>5</b>
<b>4</b>	<b>Technical data .....</b>	<b>9</b>
<b>5</b>	<b>Operation .....</b>	<b>11</b>
5.1	Unpacking and setting up .....	11
5.2	Start microscope software (S-EYE).....	13
5.3	User interface and functions of the S-EYE microscope software.....	14
5.3.1	Effect – Setting the camera parameters.....	15
5.3.2	Capturing and playing back images and videos .....	16
5.3.3	Transferring picture and video files to a PC .....	17
5.3.4	Measurements .....	18
5.3.5	Image analysis .....	22
<b>6</b>	<b>Service .....</b>	<b>25</b>
<b>7</b>	<b>Disposal.....</b>	<b>25</b>
<b>8</b>	<b>Further information.....</b>	<b>25</b>

# **1 Before use**

## **1.1 General notes**

You must open the packaging carefully, to make sure that none of the accessories in the packaging fall on the floor and get broken.

You should also avoid getting dirt or finger prints in the area of the camera sensor, because in most cases this will reduce image clarity.

The sensors and electronics inside the camera are extremely sensitive to light. For this reason never leave the camera in direct sunlight for long periods of time.

Where possible the tablet should not be used in humid environments. Using it in an environment which is always dry will automatically increase the service life.

## **1.2 Storage**

You should ensure that the device is not exposed to direct sunlight, temperatures which are too high or too low, vibrations, dust or a high level of humidity.

The ideal temperature range is between 0 and 40°C and a relative humidity of 85% should not be exceeded.

Sudden temperature fluctuations may cause fog inside the tablet. The tablet should therefore be stored in a bag or have a protective sleeve to protect it from these fluctuations.

## 2 Scope of supply



Tablet camera

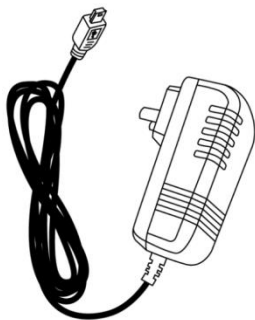

Power adapter



User Instructions



**3 Nomenclature**



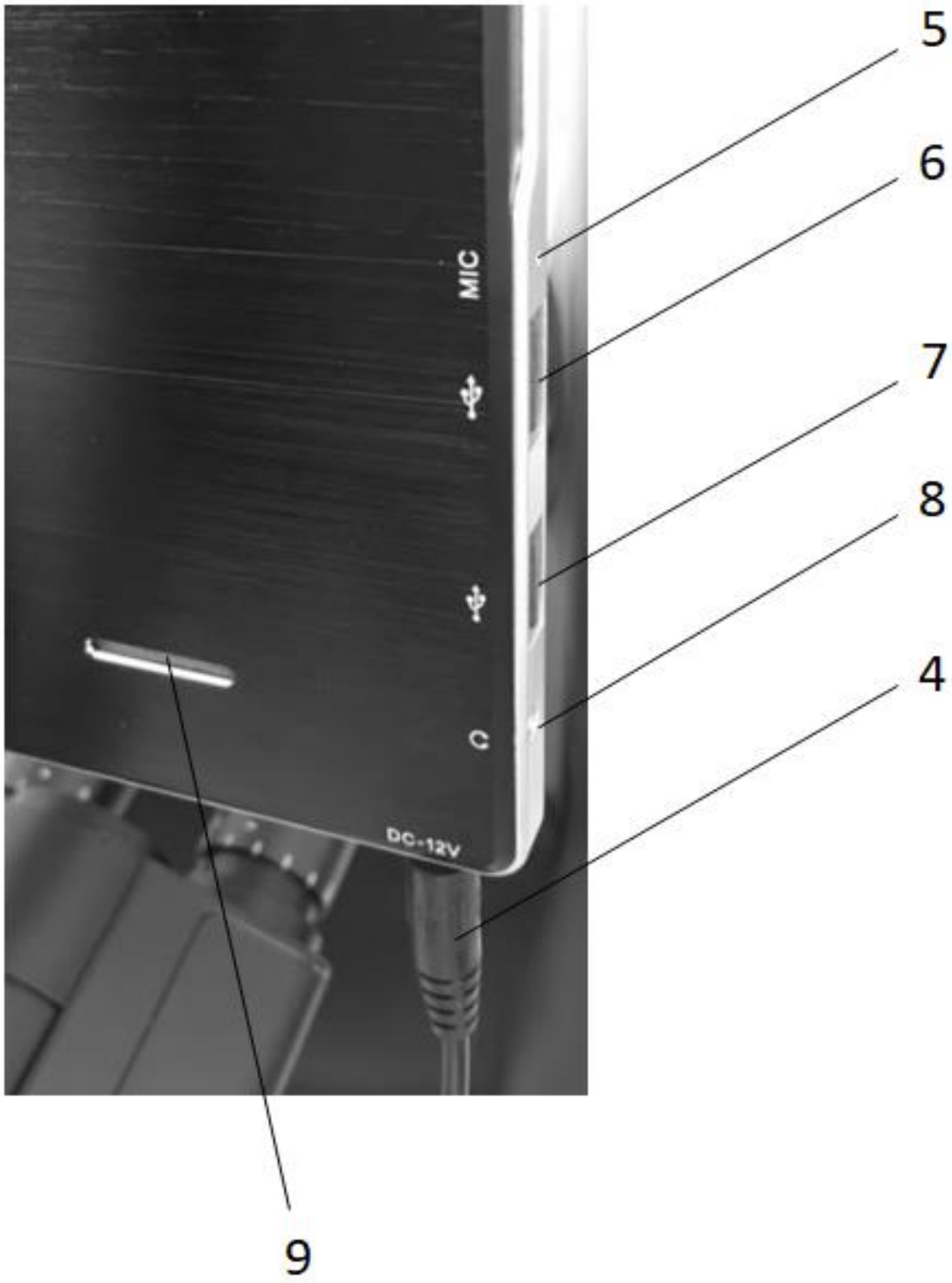

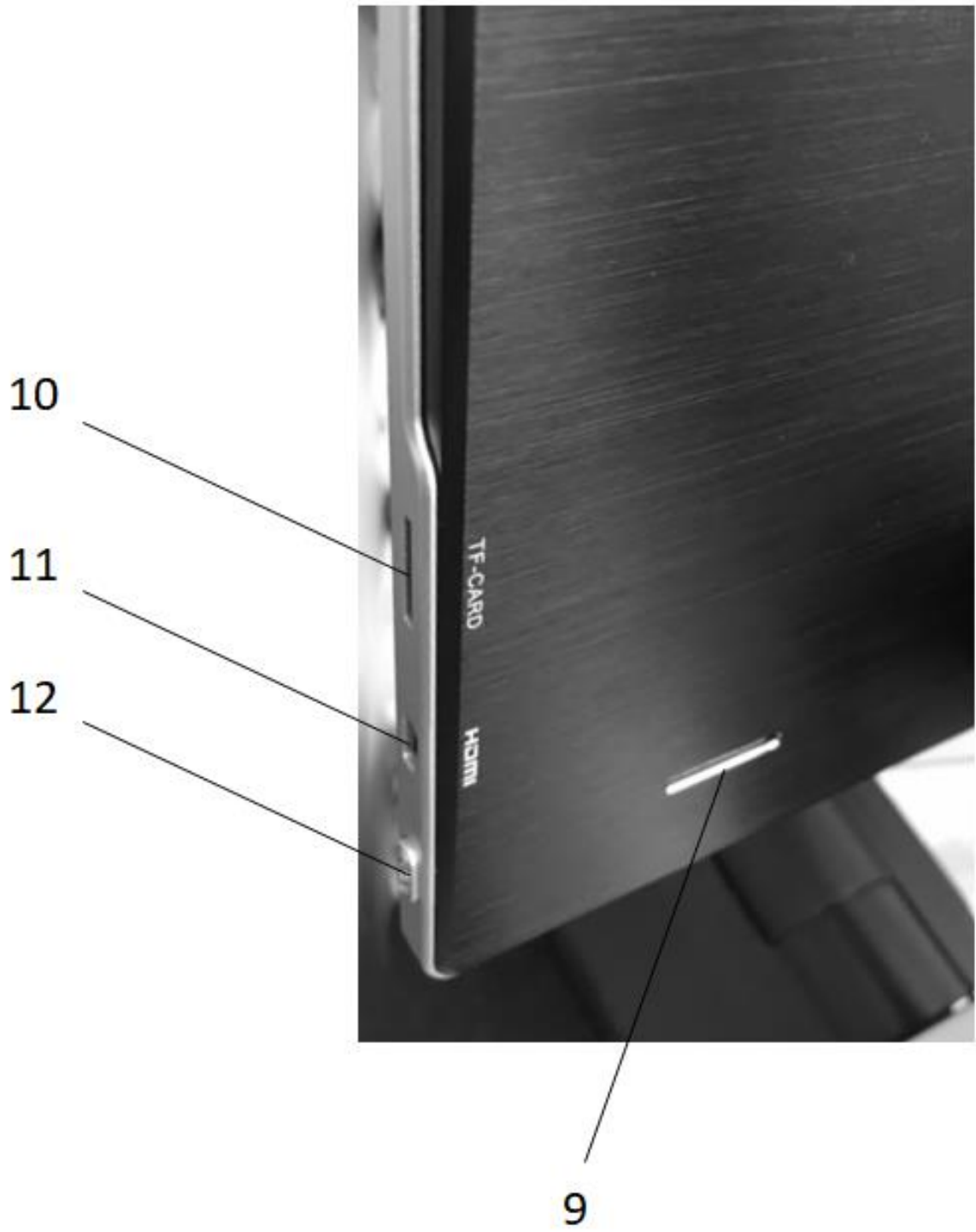

<b>Part number</b>	<b>Description</b>	<b>Part number</b>	<b>Description</b>
1	Tablet / Touch display	7	USB port PC mouse connection
2	Camera housing	8	Connection socket for headphones
3	Camera sensor	9	Loud speaker
4	Power connector	10	Micro SD slot
5	Microphone	11	Micro HDMI port
6	USB port	12	On/Off switch

## 4 Technical data

Screen	9.7" LCD touchscreen
CPU	Quad Core Cortex-A17; 1.8 GHz
Screen resolution	2048x1536 pixels
Sensor	1/2.5" CMOS
Frames per second (fps)	30 fps @ 1024x768
Pixel size	2.2 $\mu\text{m}$ x 2.2 $\mu\text{m}$
Photo format	JPEG
Input voltage	12 V DC (no battery operation)
Operating system	Android 5.1
Interfaces	WLAN, USB 2.0, Micro SD, Micro HDMI
App	S-eye
Language	English
Packaging dimensions	275x230x85 mm
Weight	Without packaging: 0.65 kg With packaging: 1.05 kg

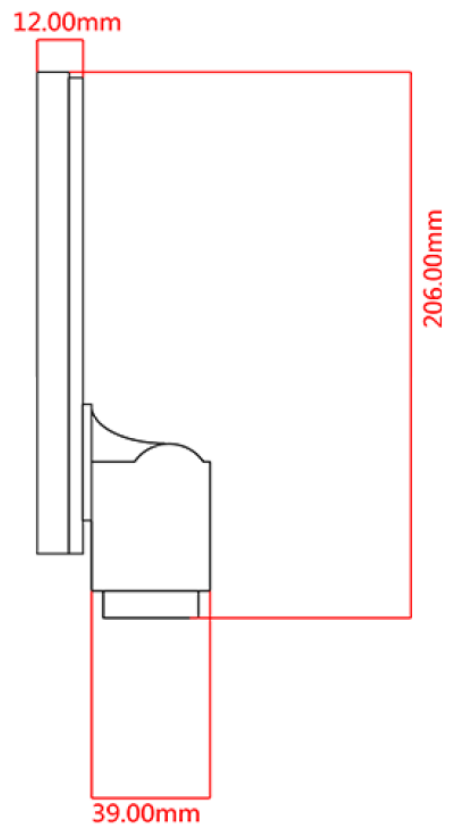
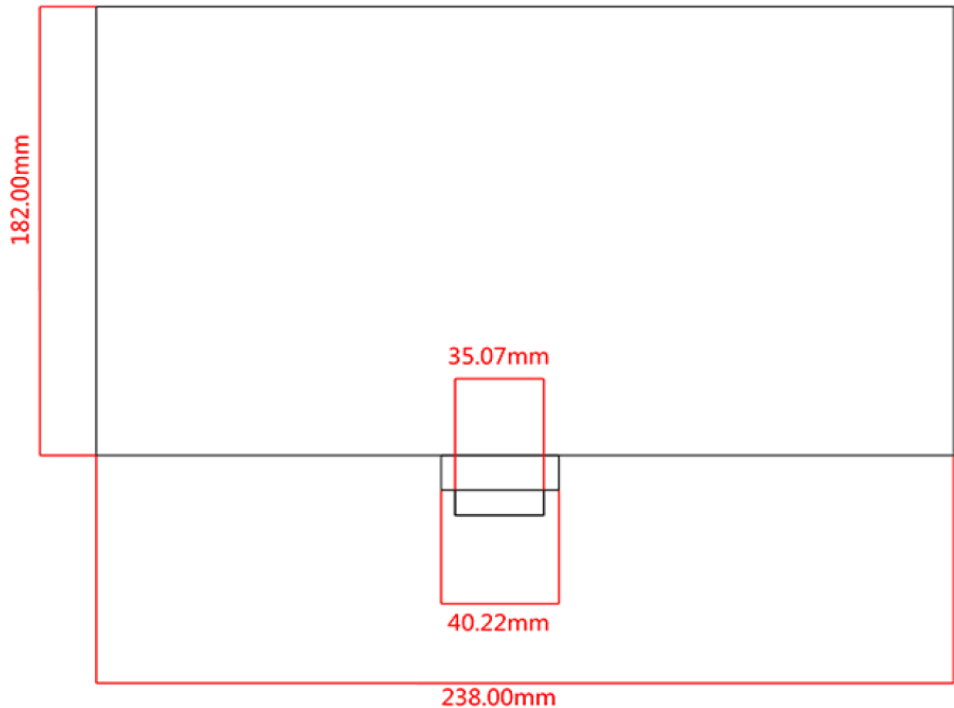

## 5 Operation

### 5.1 Unpacking and setting up

1. Take the tablet camera and power adapter out of the packaging and remove the packaging sleeves
2. Remove the protective film from the display of the tablet
3. Undo the screws on the cover on the back of the camera and remove the protective film underneath
4. Fit the tablet camera to the trinocular connection of the microscope

**To do this you need a C-mount adapter, which fits the microscope you are using. (For an example, see figure on page 12)**

5. Connect the power supply using the power adapter

**The power connector is located on the left on the underside of the tablet**

**Tablet camera**



**C-mount adapter**



**Microscope**





## 5.2 Start microscope software (S-EYE)

1. Press the On/Off switch in order to start the tablet (operating system: Android)

To do this the tablet must have a permanent power supply  
Battery operation is not possible

2. The S-EYE microscope software usually starts automatically

If this does not happen, then this App (from the desktop of the tablet) can be started manually (touchscreen)

*See figure below*

3. To operate the tablet/microscope software easily, you can connect a PC mouse to the USB port at any time



*Tablet start screen*

### 5.3 User interface and functions of the S-EYE microscope software

S-EYE offers its users an extensive range of functions and thereby guarantees the very best digital sample analysis.

**As well as live image transfer, the following tools are also included:**  
*(can be selected on the righthand edge of the scree)*

1. Effect – Setting the camera parameters
2. Measure – Various measuring functions
3. Playback – Image and video playback/image analysis
4. Snap – Image capture
5. Record – Video recording
6. Setting – General settings

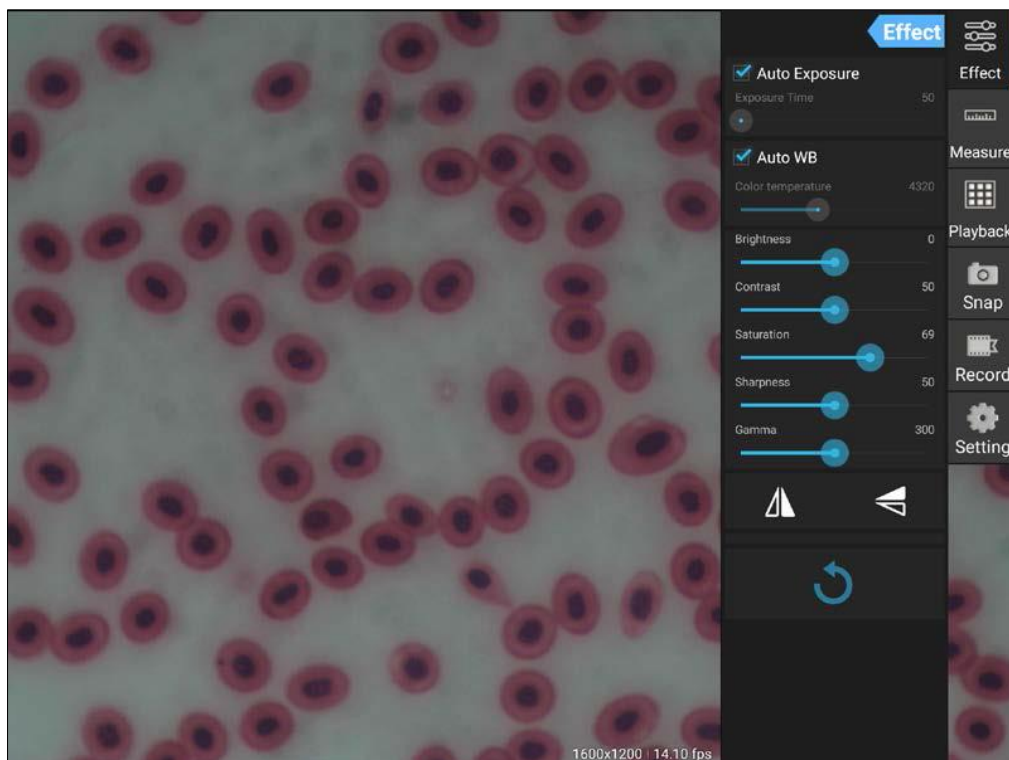

### 5.3.1 Effect – Setting the camera parameters

If the imaging from the live transfer is not satisfactory, then there are a few options to optimise this imaging, using the “Effect” program category.

#### 1. Exposure

- Auto mode:  
Exposure time adjusts automatically
- Manual mode:  
Exposure time is adjusted manually

#### 2. Auto WB (white balance)

- Auto mode:  
Colour temperature adjusts automatically
- Manual mode:  
Colour temperature is adjusted manually

#### 3. Further image processing

- Brightness
- Contrast
- Saturation
- Sharp
- Gamma

#### 4. Flip function

- Horizontal image mirroring
- Vertical image mirroring

#### 5. Reset

The settings implemented for image processing can be saved under four different profiles.

To do this click on the following symbol: 

You can also reset to the original settings using the “factory” profile.

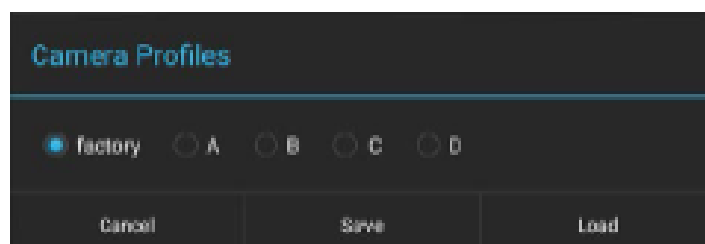
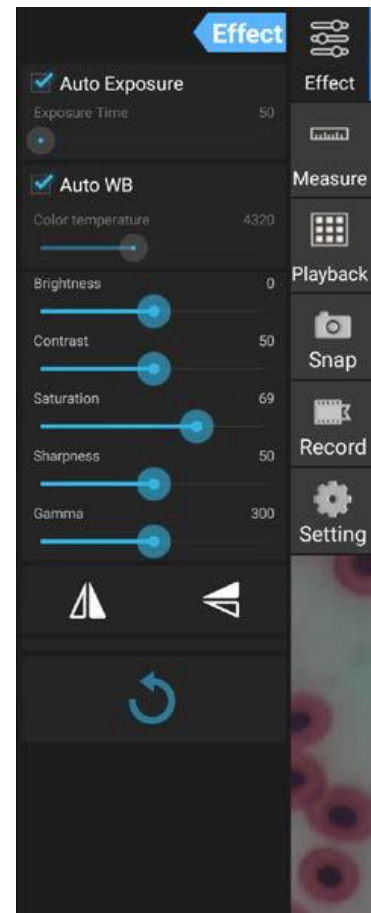

### 5.3.2 Capturing and playing back images and videos

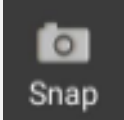
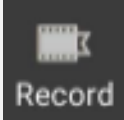
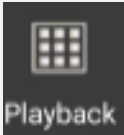
 <p>Snap</p>	<p>Click on the Snap button to capture an image.</p> <p><i>You can set the image size in the “Setting” program category under “Picture Size”.</i></p>
 <p>Record</p>	<p>Click on the Record button to record a video.</p> <p><i>Depending on the video size selected for live transfer (“Setting” program category under “Preview Size”), videos with a size of up to 1080p (Full-HD) can be recorded.</i></p>
 <p>Playback</p>	<p>All images and videos are saved and can be recalled using the Playback button. In order to open the required image or video, you need to double click.</p> <p><i>You can specify the default storage location for images and videos in the “Setting” program category under “File Storage Path”</i></p> <p><i>Using the “Popup file dialog when saving file” you can set whether the dialogue window should appear to confirm each image or video.</i></p> <p><i>Under “Enable built-in image viewer” you can set whether images can be opened using the standard Android gallery or in the built-in image display program (see 5.3.4 Image analysis).</i></p>

### 5.3.3 Transferring picture and video files to a PC

To transfer the created picture and video files to a PC, the following steps must be carried out:

1. Insert the USB-stick to the tablet (folder structure will be created)
2. Start the **Explorer** in the Android menu (minimise S-EYE software for this purpose)
3. Open **NAND FLASH** storage
4. Scroll to the **S-EYE** folder and open it
5. Select and open the folder **Pictures**
6. Click on **Multi** in the menu bar and select the files you want
7. Then click on **Editor** and select **Copy**
8. Go to **Home** and select **USB storage(HOST)**
9. Click on **Past** in the **Editor** and the selected files will be saved

The USB-stick can then be removed and plugged into the PC.

### 5.3.4 Measurements

In order to be able to take measurements, calibration must be carried out first, which will synchronise the magnification settings of the microscope and the image characteristics of live transfer on the tablet camera.

#### Calibration:

1. Place the object holder with integrated scale onto the stage of the microscope
2. Click on the Measure button
3. Click on “Add” (or “+”) in the lower area of the “Calibrations” area

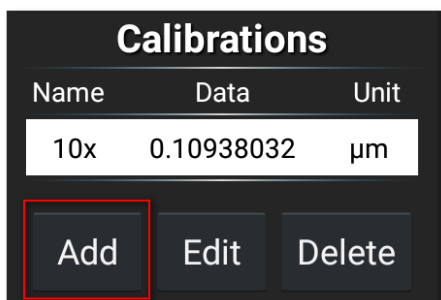

4. Follow the instructions which are displayed, step by step

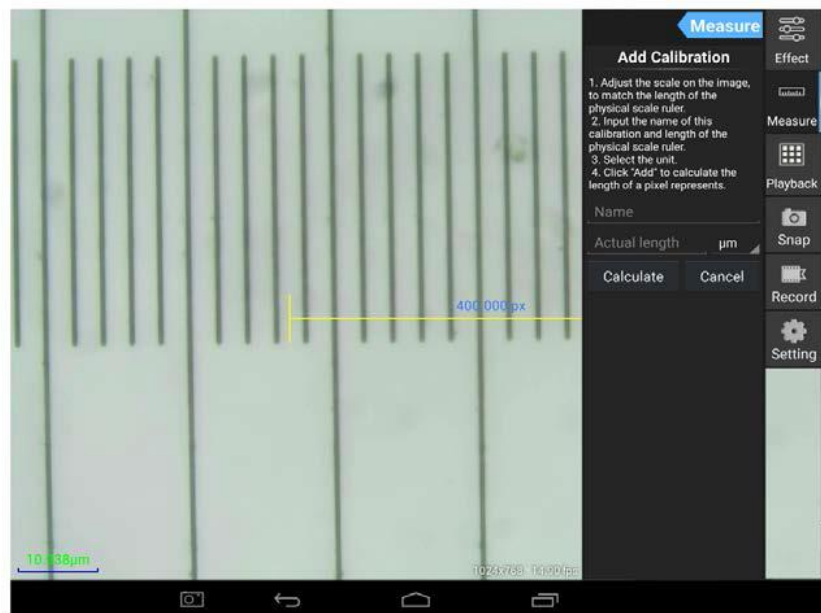

- Adjust the scale on the image to match the length of the physical scale ruler  
You can move the scale or alter the length using the touch function.

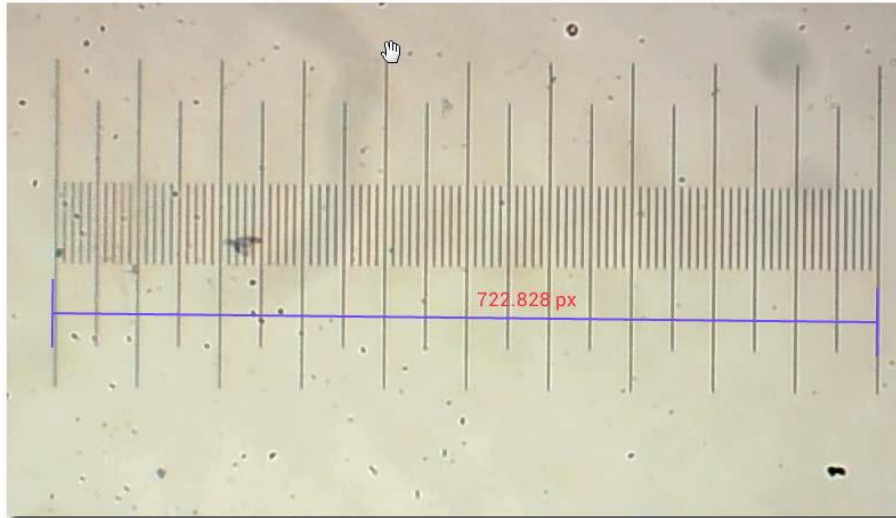

In the example shown, a scale with a fine division of 0.01 mm (10 μm) is used. The total length is 1000 μm

- Enter an appropriate name for the calibration.  
Usually the lens magnification set for the microscope is selected.  
In the example here: 4x.  
It is also vital to specify the length of the part as established using the scale, as well as the preferred measuring unit for the measurement.  
In the example here: 1000 μm.

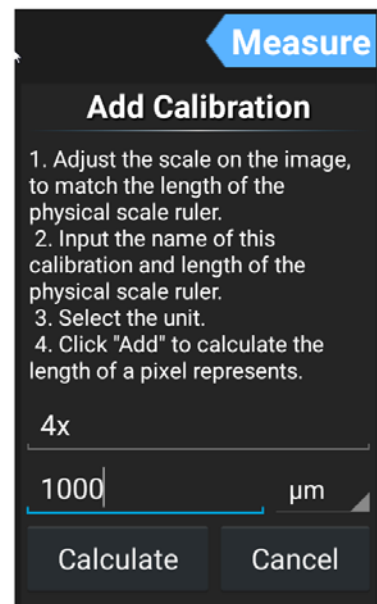















- Click on “Calculate” in order to save and close the calibration.  
This procedure must be carried out again for other lens magnifications.

Calibrations		
Name	Data	Unit
4x	1.3842217	μm
10x	0.10938032	μm

Add Edit Delete

## Measuring tools:

Symbol	Function	Description
	Counting	Adding points which are marked with the consecutive numbers
	Line	Measuring the distance between two points
	Rectangle	Measuring the length, width and area of a rectangle
	Circle	Measuring the radius and area of a circle <i>Different methods are available for creating a circule</i>
	Cross line	Adding a cross line <i>Multiple x or y axes possible</i>
	Angle	Measuring an angle
	Double circle	Measuring the distance between two circle centres
	Perpendicular	Measuring the distance between a line and a point
	Concentricity	Measuring the radii of two circles with the same centre
	Text	Adding text annotations
	Settings	Setting the line thickness, line colour, font and font size and colour
	Save	Creating an image which contains the currently displayed measurements
	Delete 1	Delete one selected measurement
	Delete 2	Delete all measurements on the screen



**Example of a line measurement:**

1. Select a saved calibration under the “Measure” program category.

It is selected when you see white background with black text.

Calibrations		
Name	Data	Unit
4x	1.3842217	μm
10x	0.10938032	μm

Add Edit Delete

2. Click on the symbol for line measurement.

Then the measuring line along with the measurements will be displayed in the live image transfer. This can be moved as required and the length can be altered.

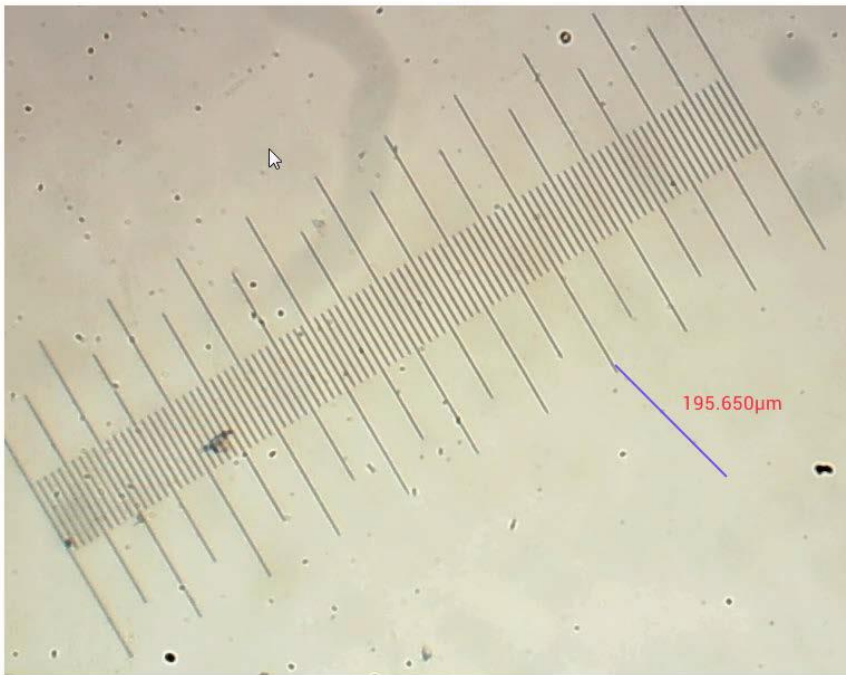

### 5.3.5 Image analysis

The built-in image display program offers the user various options for image analysis. In order to be able to use this tool, it must first be activated in the “Setting” program category.

→ Tick the box for “Enable built-in image viewer”

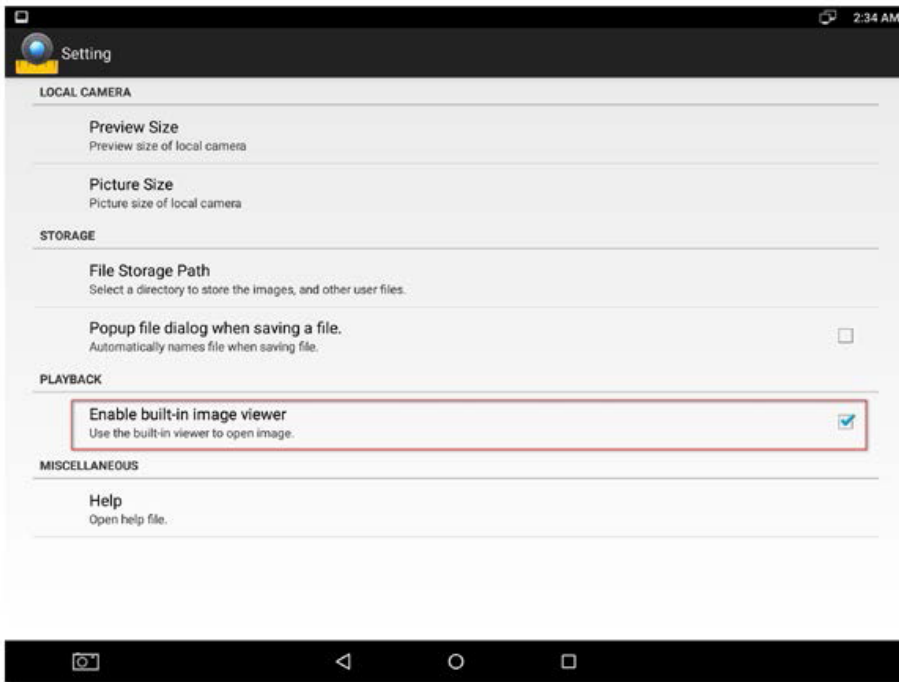

As soon as an image is opened in the “Playback” program category, this is then displayed on the S-EYE image display.

Further images can be opened here or new images can be captured at this point.

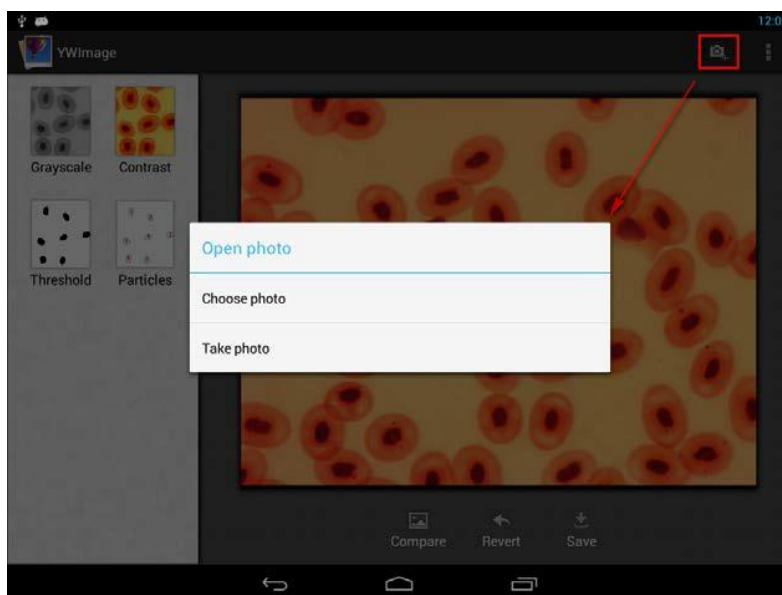

Four different instruments for image processing or image analysis can be implement with this program:

1. **Greyscale**  
“GREYSCALE” function

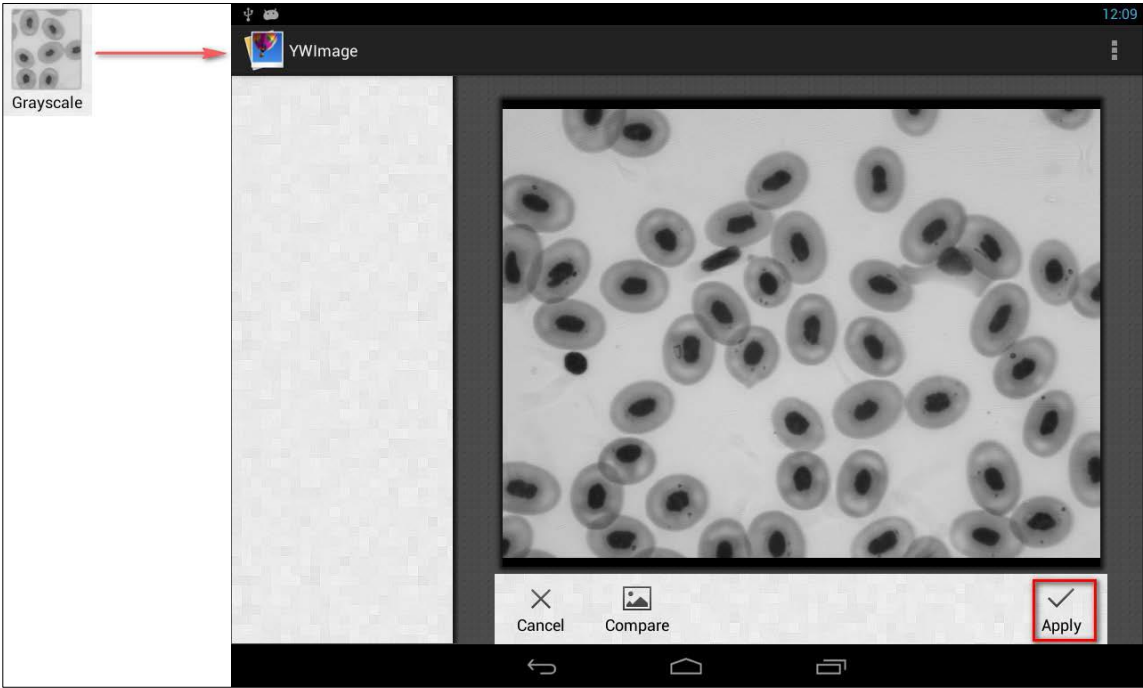

2. **Contrast and brightness**  
“CONTRAST” function

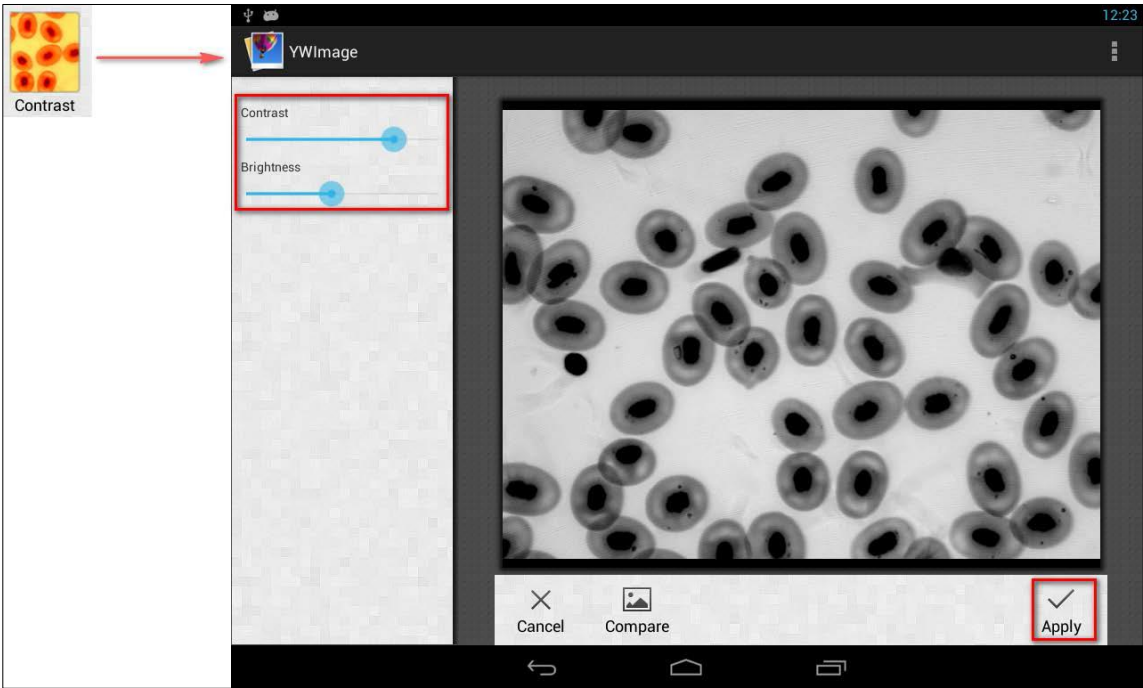

### 3. Threshold "THRESHOLD" function

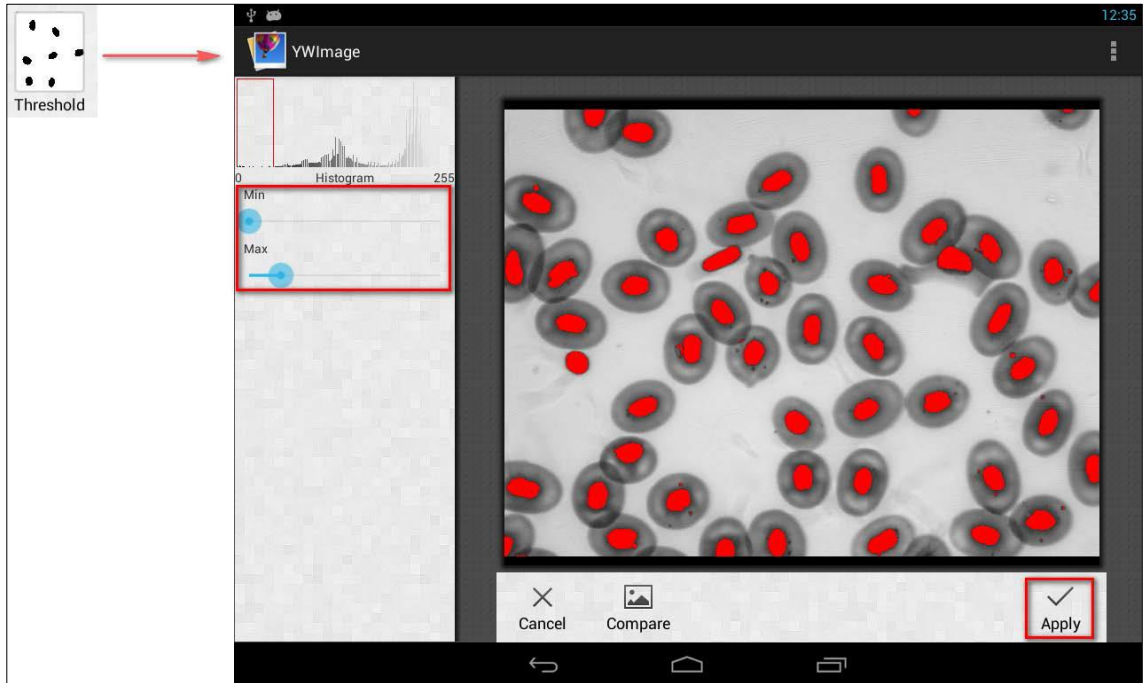

### 4. Particle analysis "PARTICLES" function

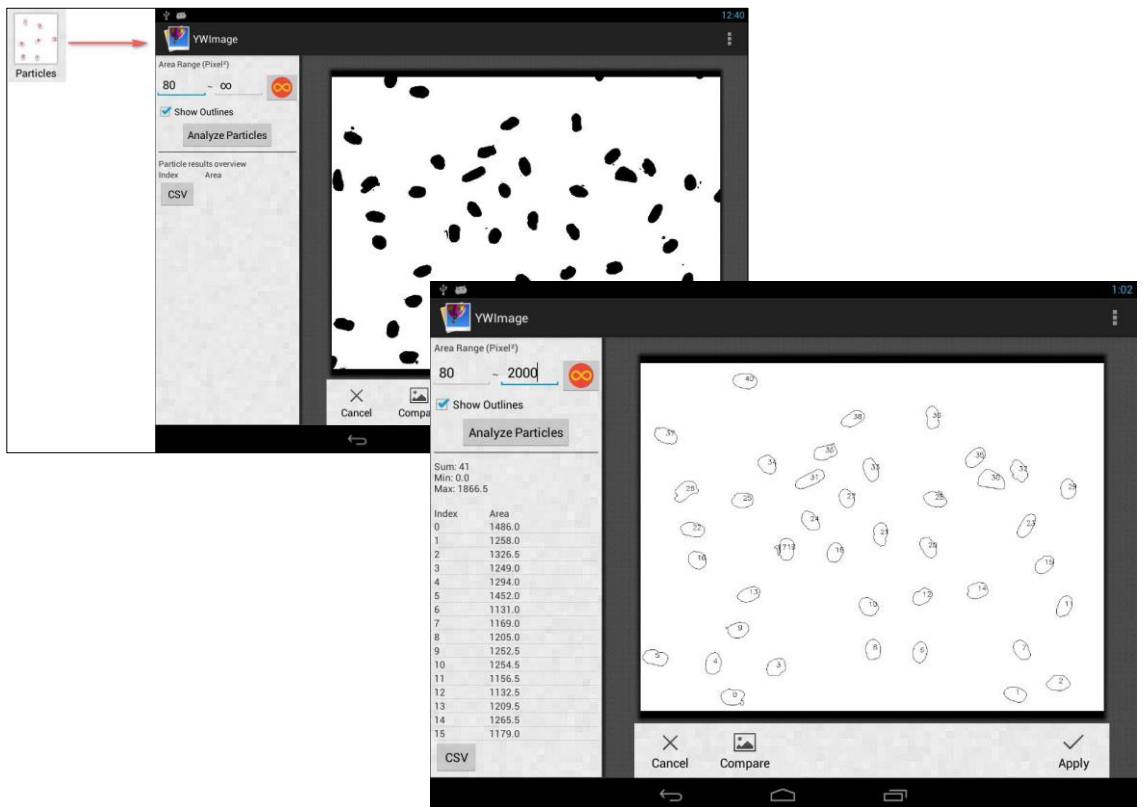

## 6 Service

If, after studying the user manual, you still have questions about commissioning or using the microscope, or if unforeseen problems should arise, please get in touch with your dealer. The device may only be opened by trained service engineers who have been authorised by KERN.

## 7 Disposal

The packaging is made of environmentally-friendly materials, which you can dispose of at your local recycling centre. Disposal of the storage box and device must be carried out by the operator in accordance with all national or regional laws in force in the location of use.

## 8 Further information

The illustrations may differ slightly from the product.

The descriptions and illustrations in this user manual are subject to change without notice. Further developments on the device may lead to these changes.



All language versions contain a non-binding translation.  
The original German document is the binding version.