



OPERATING MANUAL
21 CFR TOUCH SCREEN MICROBALANCE

CM series

1. Introduction .

The models of the **CM Series** are weighing instruments of special and high accuracy designed for the measurement of mass, covering a range from 60 kg to 500 kg.

CM Series meet the highest requirements on the accuracy and reliability of weighing results through the following features:

- Filtering for unfavorable ambient conditions, such as vibration, drafts, etc.
- Stable and repeatable weighing results
- Excellent readability under any lighting conditions
- Rugged, durable weighing system

These weighing instruments speed up your simple routine applications through following features:

- Extremely fast response times
- Built-in applications
 - Weighing
 - Percent weighing
 - Differential weighing
 - Piece counting
 - Animal weighing
 - Custom Unit
 - Limit check
 - Peak weighing
 - Statistics
 - Audit Trail Report



1.1 Warnings and Safety precautions

The balance has been constructed in accordance with the OIML as well as international regulations and standards for operation of electrical equipment, electromagnetic compatibility, and stipulated safety requirements. Improper use or handling, however, can result in damage and/or injury.

To prevent damage to the equipment, please read these operating instructions carefully before using your balance.

Keep these instructions in a safe place.

Follow the instructions below to ensure safe and trouble-free operation of your balance.

-  Do not use this balance/scale in a hazardous area/location.
-  If you use electrical equipment in installations and under ambient conditions requiring higher safety standards, you must comply with the provisions as specified in the applicable regulations for installation in your country.
-  Make sure that the voltage rating printed on the AC adapter is identical to your local line voltage.
- The only way to switch the power off completely is to disconnect the AC adapter.
- Connect only Aczet accessories and options, as these are optimally designed for use with your Aczet balances.
- Note on Installation:

The operator shall be responsible for any modifications to the equipment and for any connections of cables or equipment not supplied by us and must check and, if necessary, correct these modifications and connections. On request, Aczet will provide information on the minimum operating specifications

- Protect the DC adapter and the weighing instrument from contact with liquids.
- When cleaning your balance, make sure that no liquid enters the balance housing; use only a slightly moistened cloth to clean the balance.
- Do not open the balance/scale housing. If the seal is broken, this will result in forfeiture of all claims under the manufacturer's warranty.
- If you have any problems with your balance contact your local Aczet Office, dealer or service center

1.2 Getting Started

Storage and Shipping Conditions Do not expose the balance/scale to extreme temperatures, blows, shocks, vibration or moisture. **Unpacking the Equipment**

After unpacking the balance/scale, check it immediately for any visible damage as a result of rough handling during shipment if you see any sign of damage: Contact your local Aczet Office, dealer or service center.

It is a good idea to save the box and all parts of the packaging until you have successfully installed your balance. Only the original packaging provides the best protection for shipment. Before packing your balance, unplug all connected cables to prevent damage.

Cautionary notes

Micro balances may not be operated in hazardous areas. Before attachment of the DC adapter, check whether the imprinted voltage value matches the local supply voltage.

If it does not, contact your local ACZET dealers. Micro balance may only be used indoor in dry environment.

Accessories supplied

The equipment supplied includes the following:

1. Balance with control unit and Touch screen indicator
2. Touch screen Module Display with 2 nos serial ports for statistical printer and weighing indicator
3. Leveling feet
4. Operating Manual
5. DC adapter- 12vdc, 2 amp and 13Vdc, 1.5 amp
6. Base Plate S.S. (CM)

1.3 Layout :

Model: CM series

1. Balance with control unit.
2. Touch screen Display
3. Glass chamber
4. Weighing pan
5. Leveling feet
6. Spirit Level

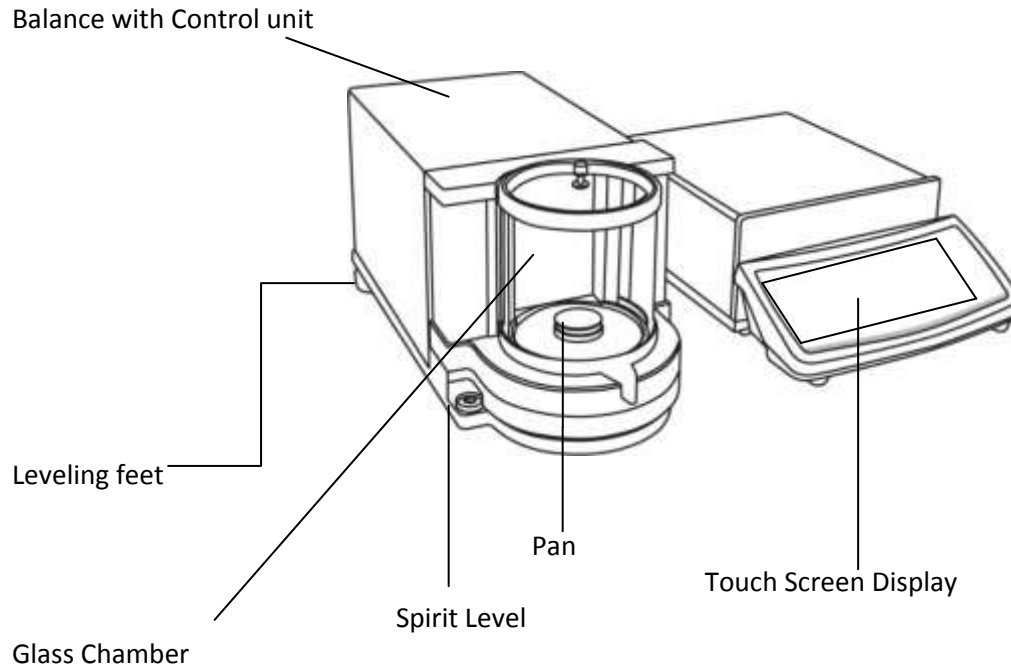

2. Setting up the Balance.

2.1 Location

The optimum location

The correct location makes an important contribution to the accuracy of the weighing results of high-resolution analytical and precision balances. Hence ensure a stable, vibration-free position as horizontal as possible.

Avoid

- Direct sunlight
- Excessive temperature fluctuations,
- Drafts (Power ----- Air Conditioning System, Fans can also cause drafts)

The best position is on a stable bench in a corner protected against drafts as far possible from doors, windows, radiators or the ventilation slots of air conditioners.

2.2 Warm Up

Warm-up Time

To deliver exact results, balance must warm up to operating temperature for as lasted below before the first weighing operation is carried out. Using Verified Balances as Legal Measuring Instruments in the Micro balance must warm up for at least 24 hours after initial connection to DC power.

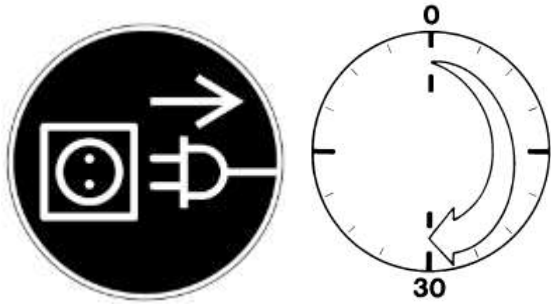

3 Operating procedure:

3.1 Power ON

Connect DC Adaptors of Touch screen module and Micro balance power plug ,then switch ON the power

- Screen we show no signal for few seconds and the display will show as below:
- It will display version number for software



Login

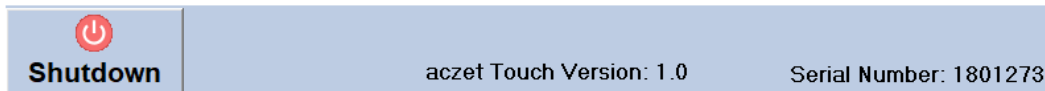

User Name	<input type="text" value="Lupin"/>
Password	<input type="password" value="*****"/>
	<input checked="" type="checkbox"/> Hide
Type	<input type="text" value="Administrator"/>



3.2 Login Menu

Following login type are available :

- Administrator**- Administrator login has complete access of weigh application, create user Id , change password, Backup & Restore etc . Expect master login.
Can create password
- IT Admin**- IT Administrator login has complete access of create user Id , change password ,Backup & Restore . Expect master login.
- User – Login** has complete access of weigh application, calibration check, View & print Audit trail report. Any number of users can be created.
- Master**- Master Login is factory mode for parameter setting. To be operated by only manufacturer.

Monday, 11 Mar 2019
09:35:47 PM



Login Lupin

User Name Lupin

Password *****

Hide

Type
 Administrator
 IT Admin
 User
 Administrator
 Master





aczel Touch Version: 1.0
Serial Number: 1801273

To Login select the Type and userName, enter password and click Login.
After Successful Login, below screen appears





 Weighing



 Percentage



 Differential



 Limit Check



 User Account



 Statistics



 Calibration



 Settings

 Animal













 Audit Report

Monday, 25 Mar 2019
11:25:42 AM





4 WORKING MODES – GENERAL INFORMATION

	<p>Weighing Means of operation: weight of a load is determined through an indirect measurement. A balance measures gravitational force which attracts the load. An obtained result is processed to a digital format and displayed in a form of measurement result.</p>
	<p>Percent Weighing Means of operation: control of percent ratio of a sample in relation to a standard (reference). Obtained data provides percent ratio on how test sample differs from the accepted standard (reference). Display shows Percentage weight in %</p>
	<p>Differential Weighing Means of operation: is one of Weighing application functions. It allows analysis of sample weight variation occurring in the course of a technological process. Display shows Differential weight in grams .</p>
	<p>Limit Check Means of operation: control of sample mass with applied thresholds. A user should specify the value of min threshold <LO> and max threshold <HI>. Display shows graph in 3 colors yellow for LOW, Green for accept, Red for High</p>
	<p>Statistics Means of operation: carried out measurements are used to calculate statistical data, such as Min, Max, deviation, etc.</p>
	<p>Calibration TO perform Calibration - Internal and External calibration .</p>
	<p>Animal Weighing Means of operation: Mass measurement takes place with application of filters dampening animal moves on a weighing pan, thus enabling obtaining a correct measurement Threshold weight result.</p>
	<p>Audit report Can View /Print audit reports Can filter User Type & record specify period</p>
	<p>User Account Can View, Add user , Modify password and disable user.</p>
	<p>Setting Factory setting parameter. To be operated by manufacturer or service engineer</p>
	<p>Log off Switches back to Login menu screen</p>

4.1 WEIGHING

Press  icon for weighing mode. Following display appears on screen

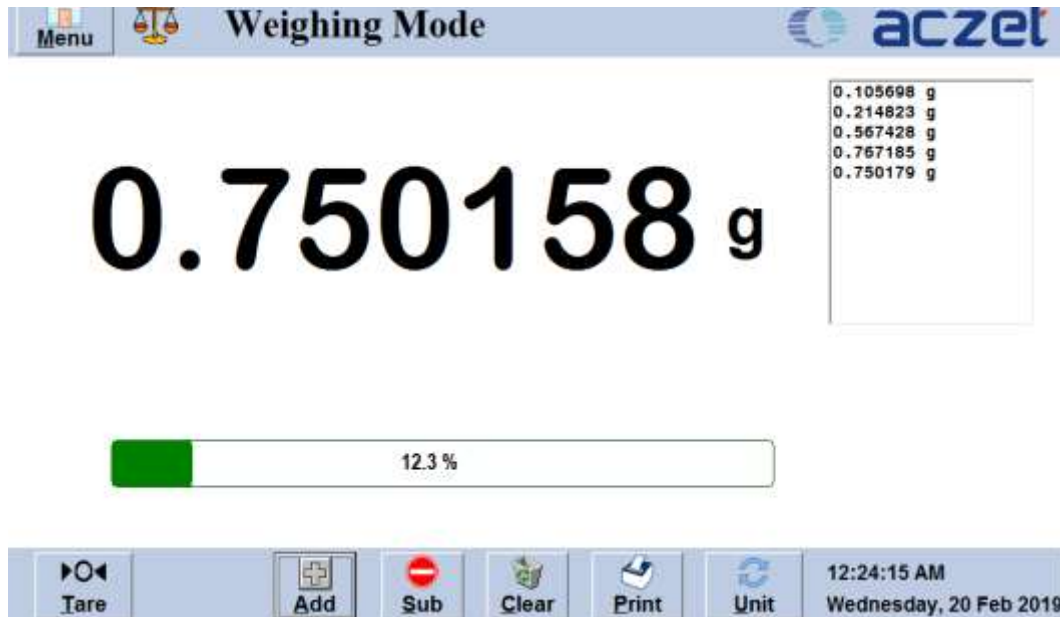

Purpose

The basic weighing function is always accessible and can be used alone or in combination with an application program.

Features

- Tare: To clear the value to make display zero.
- ADD : To add the weights one by one
- SUB : To subtract the weight reading one by one
- Clear: To clear the added weights. Once the Clear button is press all memorized data will be cleared.
- Print: to print current weighment.
- Unit: to toggle unit.

Weighing

- Place weighing sample on the weighing platform/pan.
- Read the result.
- % Bar will glow according to weight kept on the PAN.



Tare

- Place empty container on the balance.
- The weight is displayed.
- Press <Tare> key, the balance displays zero
- Add weighing sample to container, the net weight is displayed.
- If the container is removed from the balance, the tare weight will be shown as negative value.

In case if stability is not achieved & user presses



<TARE> key, display will shows "0.000000 g" until

"Display then shows "0.000 kg"



Switching of weight units

Weighing Scale can display weight values in different weight units.
The **factory setting** for (g , mg , μ g),

4.2 CALIBRATION

Calibration is one of the primary processes used to maintain instrument accuracy. Calibration is the process of configuring an instrument to provide a result for a sample within an acceptable range. Eliminating or minimizing factors that cause inaccurate measurements is a fundamental aspect of instrumentation design.

To obtain weighing results, the balance must be matched to the acceleration due to gravity at its location.

Calibration is necessary

- Before the balance is used for the first time.
- At regular intervals during weighing operation.
- After a change in location.

4.2.1 Procedure for Internal Auto calibration:

To obtain accurate results, the balance must be connected to the power supply and allowed to warm up to the operating temperature as described. Ensure that the weighing pan is unloaded and close the doors of the draft shield (if used). Balance should be Zero before calibration.

- Press <Calibration>  key on Main menu display, below screen will display:

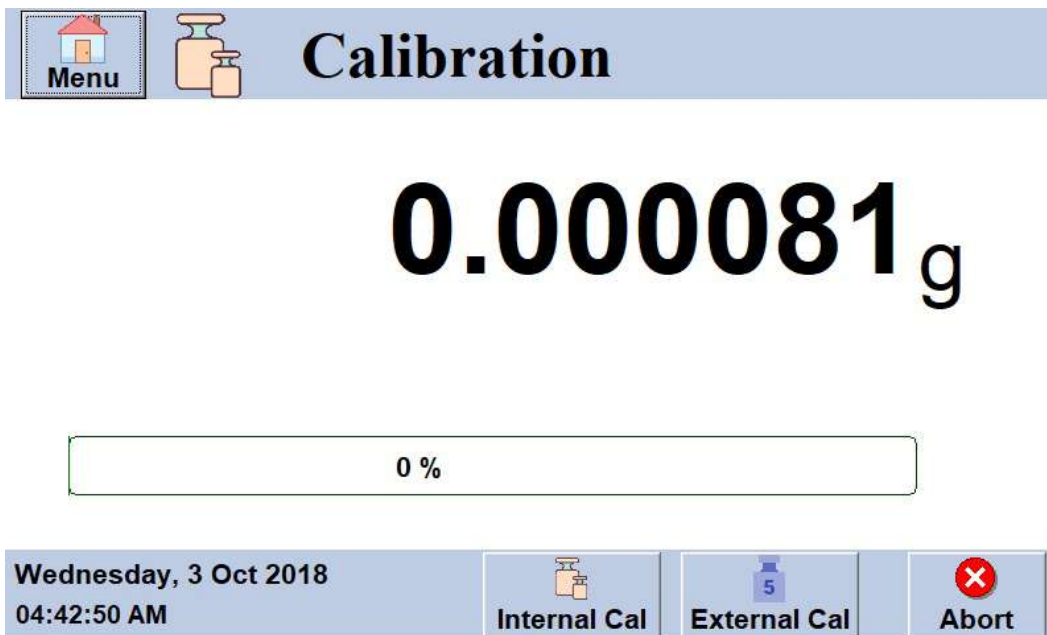

The screenshot displays the calibration interface. At the top left is a 'Menu' icon. The main title is 'Calibration' with a balance icon. The central display shows a weight of **0.000081 g**. Below this is a progress bar indicating **0 %**. The bottom navigation bar contains three buttons: 'Internal Cal' (with a balance icon), 'External Cal' (with a '5' icon), and 'Abort' (with a red 'X' icon). The date and time 'Wednesday, 3 Oct 2018 04:42:50 AM' are shown in the bottom left corner.

For Internal Auto Calibration, press icon “Internal Cal”

- <Internal Cal> Icon glows green color .
- Display will shows “Calibration initiated”

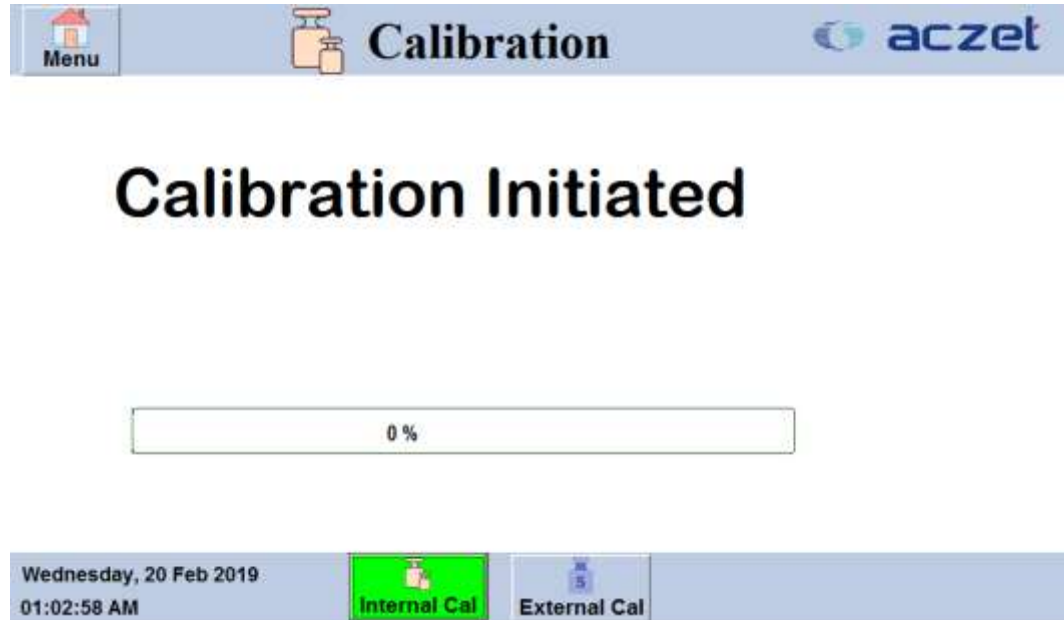

Calibration in process..

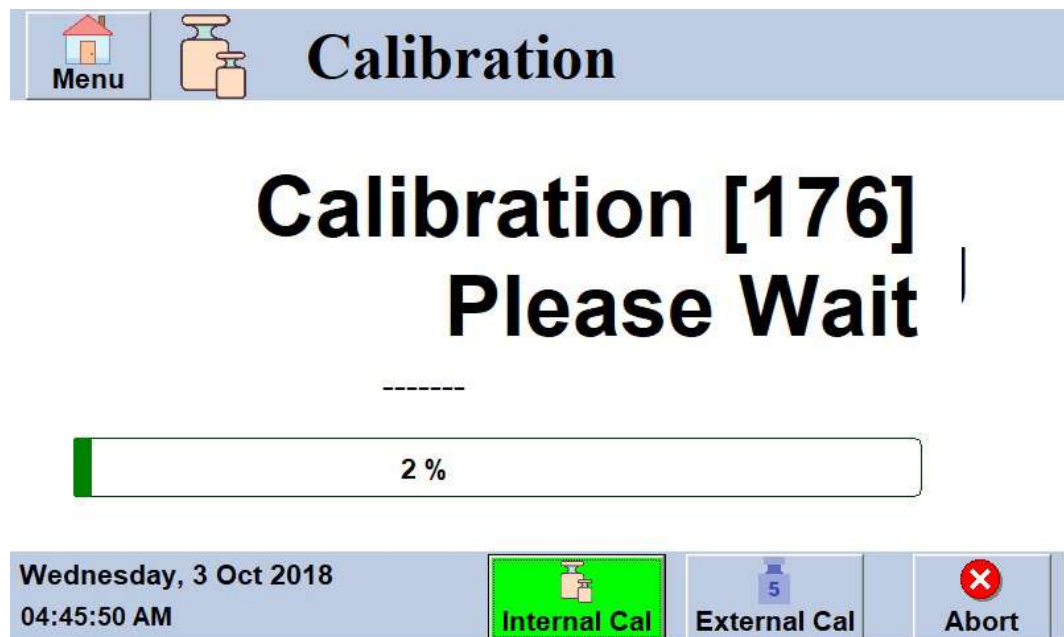

- Once the calibration is done display will show “CAL DONE”, then press “OK “. The balance will go into the weighing mode and ready for operation.

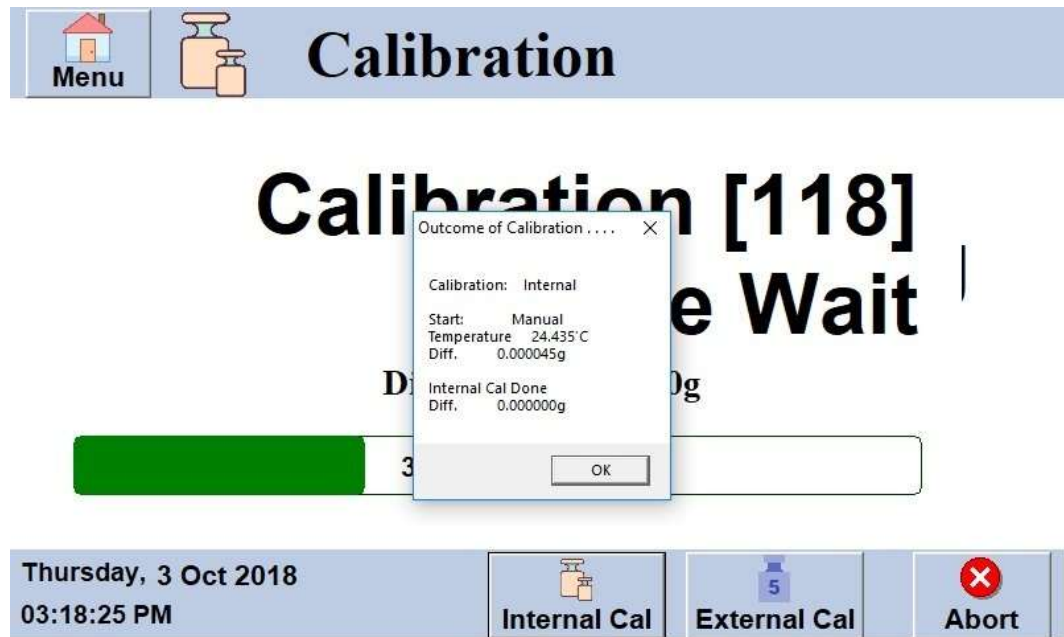

If the calibration process is terminated because of any technical issue, the display will show “Internal Cal Failed” Press OK on screen and the balance will again into the weighing mode .

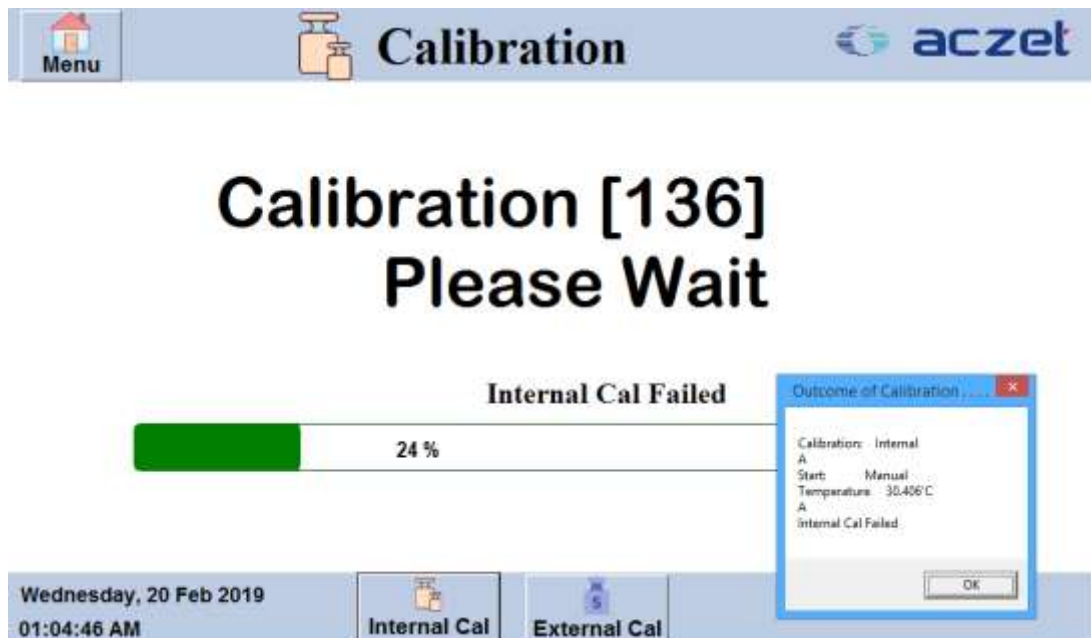

Repeat above procedure again to re-calibrate.

4.2.2. Procedure for External calibration:

For External Calibration by weight , press icon “External Cal”

- <External Cal> Icon glows green color .
- Display will shows “External Calibration initiated”



External Calibration Initiated



Calibration in process..

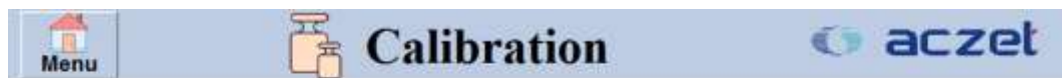

Calibration [150] Please Wait



After few seconds display show "Load 5 gram" as below

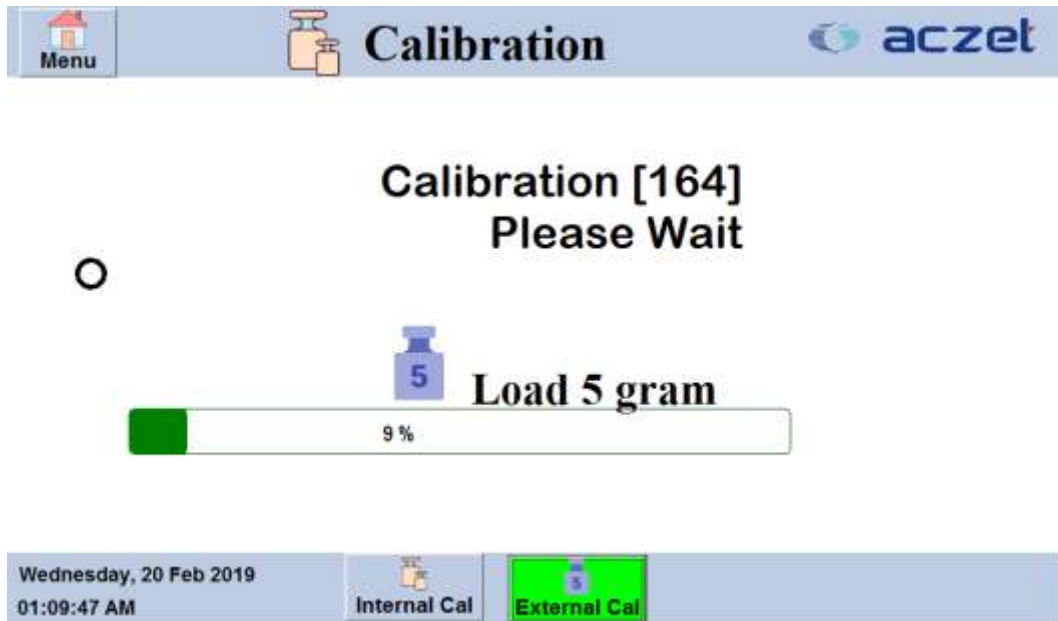

Now put standard weight of **5 gram** on weighing pan , Balance will perform external calibration automatically.

Once the calibration is done display will show "CAL DONE" , then press "OK ". The balance will go into the weighing mode and ready for operation

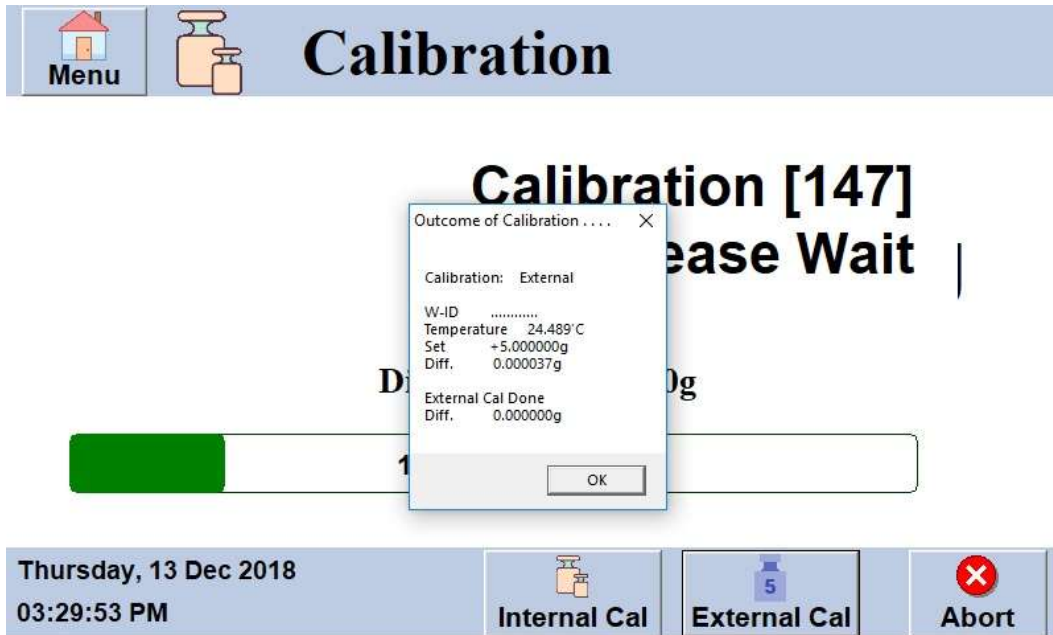

If the calibration process is terminated because of any technical issue, the display will show “External Cal Failed

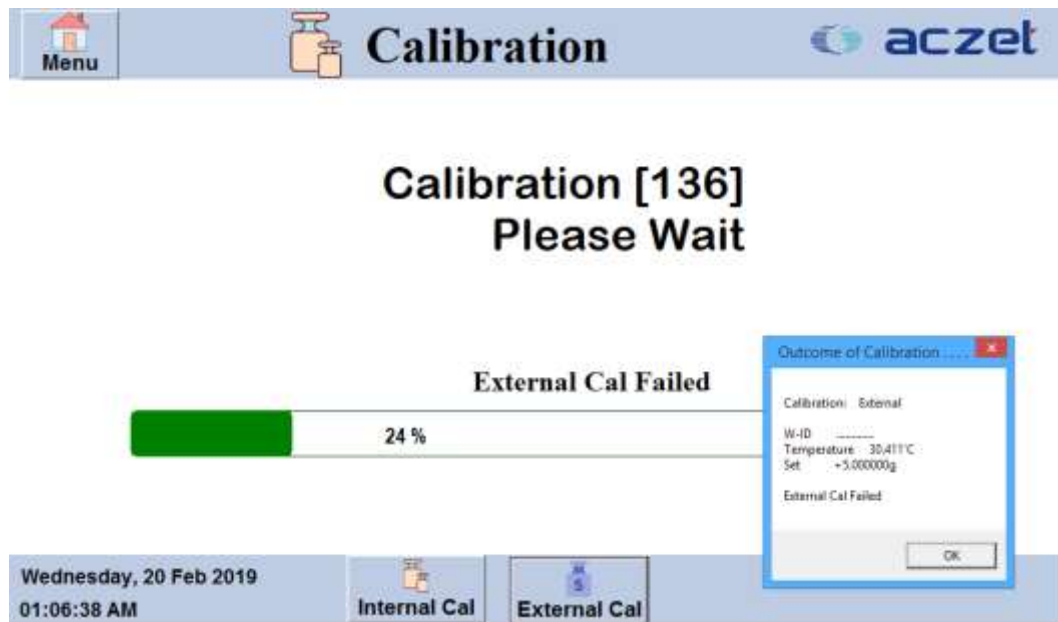

Press **OK key** and Repeat above procedure again to re-calibrate.

4.3 PERCENT WEIGHING

Percent weighing is a working mode for comparison of a measured sample with the reference mass. The result is expressed in [%].

Procedure for activation of Percent Weighing mode

Select < Percent > mode, home screen featuring percent weighing pictogram in a top bar is automatically displayed.

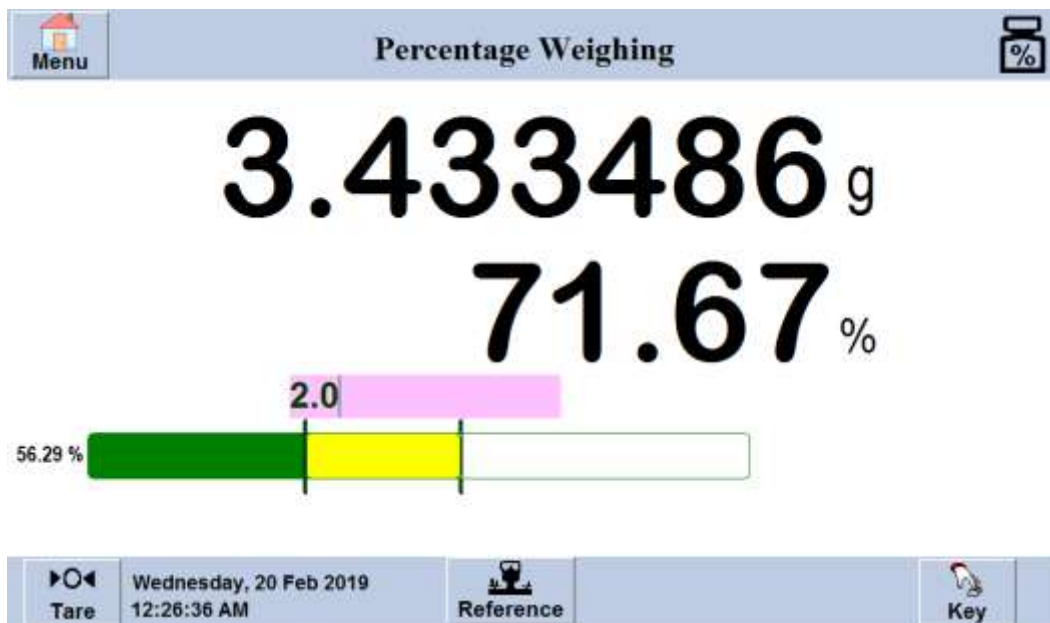

PROCEDURE 1 – determining reference mass manually

- Press <KEY> button. On-screen Internal keyboard will display
- Using an on-screen keyboard of a displayed window, enter reference mass value and press <Reference> button for confirmation.

Mass of all weighed products is compared to reference mass the weight difference is displayed in [%].

PROCEDURE 2 – accepting currently loaded mass as reference mass

- Put the sample on a weighing pan and **press <Reference >Icon**
- On measurement result stabilization, press < Determine reference mass (set as 100%)> button, dialog bar with prompts is displayed at the bottom, follow the prompts. Load the part to be weighed and upon measurement stabilization press button for confirmation,
- 100.000% indication is displayed, loaded part weight is accepted as a reference mass, and it is automatically recorded and displayed in reference mass field.
- Remove the sample form the weighing pan.
- All samples weighed afterwards are compared with the reference mass, and the display indicates the difference, expressed in [%], for each weighed sample in relation to the reference mass.

4.4 DIFFERENTIAL WEIGHING

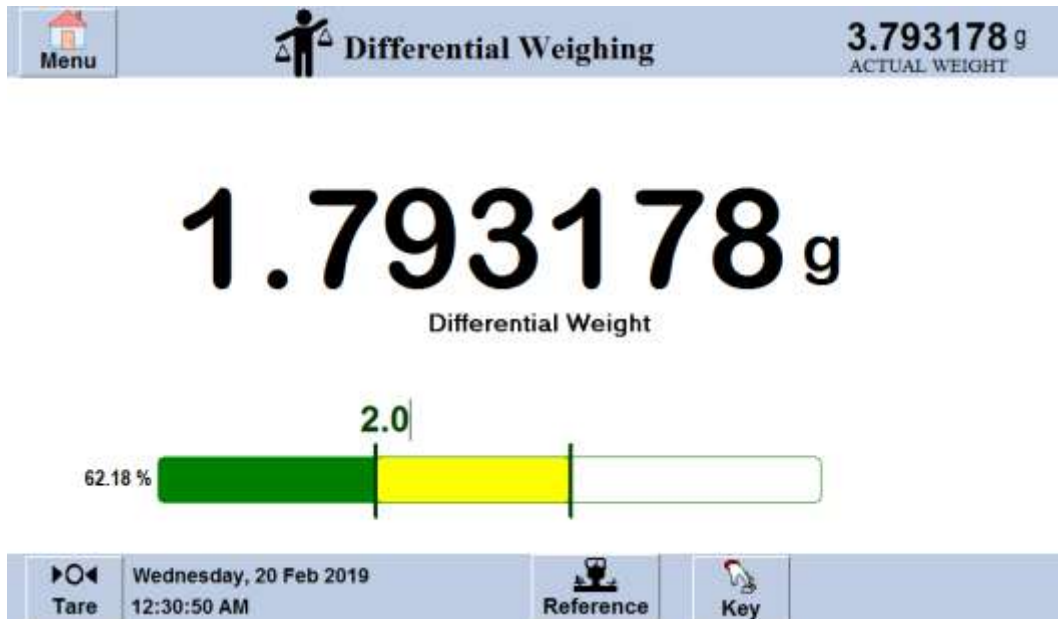

PROCEDURE 1 – determining reference mass manually

- Press <KEY> button. On-screen Internal keyboard will display
- Using an on-screen keyboard of a displayed window, enter reference mass value and press <> button for confirmation.

Mass of all weighed products is compared to reference mass the weight difference is displayed in [%].

PROCEDURE 2 – accepting currently loaded mass as reference mass

- Put the sample on a weighing pan.
- On measurement result stabilization, press <Reference > button, dialog bar with prompts is displayed at the bottom, follow the prompts. Load the part to be weighed and upon measurement stabilization press button for confirmation,
- Reference indication is displayed, loaded part weight is accepted as a reference mass, and it is automatically recorded and displayed in reference mass field.
- Remove the sample form the weighing pan.
- All samples weighed afterwards are compared with the reference mass, and the display indicates the difference, expressed in [gm.], for each weighed sample in relation to the reference mass.

4.5 LIMIT CHECK

This feature is used to check whether a sample corresponds to a preset target or is with a specific Tolerance range.

The check weighing procedure will always be carried out in **unit 'g'**.

- Set the Lower and Higher limit weight as required.
- Press <KEY > button. On-screen Internal keyboard will display
- Using an on-screen keyboard of a displayed window, enter Low value and High value .

Now place the sample on the weighing pan, display will show weight of the sample and percentage with color On bar



4.6 Animal weighing

Any type of movement can prevent a scale from registering a stable weight. That's why weighing scale manufacturers have developed specialist weighing equipment that is well-suited for weighing all types of animals /livestock cattle and liquid etc. For the most accurate results, it's important to use a weighing scale with an animal/dynamic weighing function. This means the scale has the ability to provide an average Threshold weight based on the force exerted by the animal or liquid over an extended period of time. Once the scale completes the internal calculation, it displays an Average Threshold weight.

PROCEDURE

- Press the <Animal > key on main menu on the screen,
- Put the animal on weighing pan, then Press Start key animal weighing will start as shown in below figures
- Default time for animal weighing is set to 10 seconds.



- Once it is completed the above reading will show you the normal weighing reading and the bellow reading will freeze animal average Threshold weight reading.

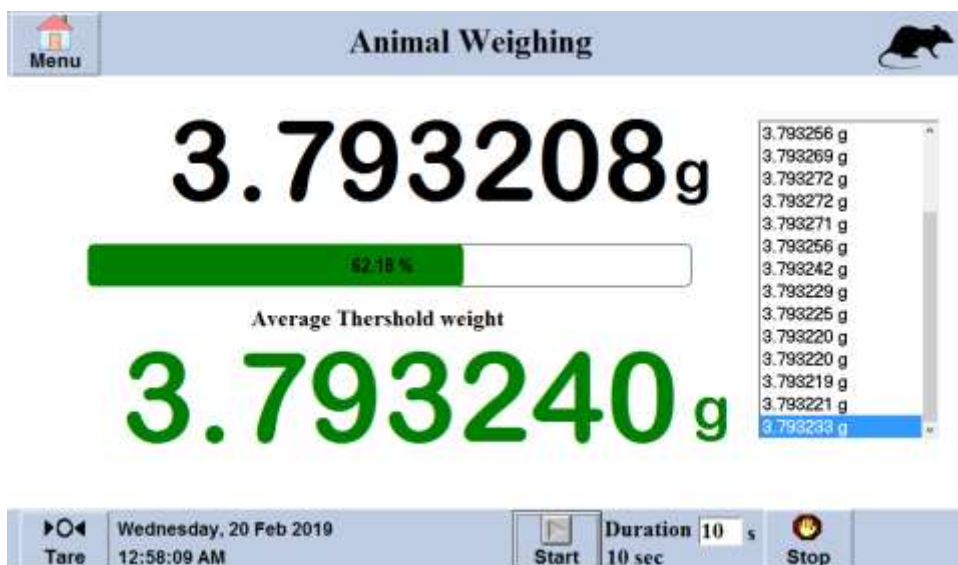

4.7 STATISTICS

Press Statistic Icon on main menu, below screen will appear.

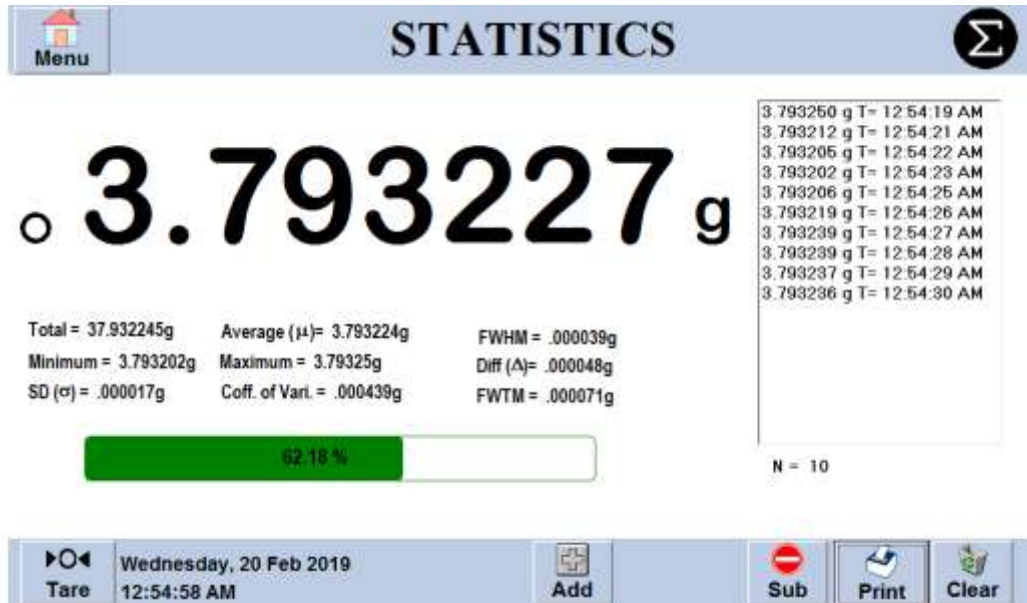

PROCEDURE

- Place sample on the weighing Pan.
- Press **<Add >** key to record the sample weight. Display will show weight of first sample in right corner of the screen .
- Similarly add number of samples you desire to know statistics .Display will result as Total weight, Average weight, Min. weight, maximum weight etc.
- Press**<Sub>** key to remove the recorded weight reading.
- To Print Statistics report, **press <Print >** icon.
- Clear button to clear the recorded weight.

To return back to main menu , press **<Menu >** icon .

4.8 USER ACCOUNT

Press  icon, following display screen appears on screen.

These function you can View, Add user , Modify password and disable user.

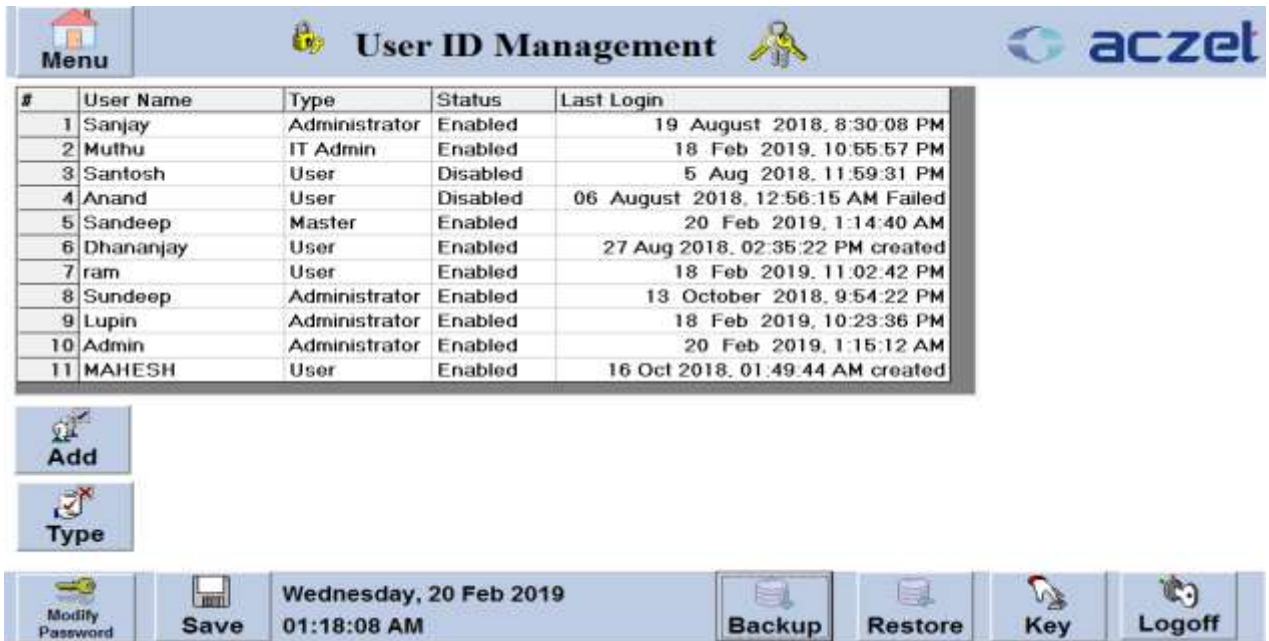

The screenshot shows the 'User ID Management' interface. At the top, there is a 'Menu' button, a lock icon, the title 'User ID Management', and the 'aczel' logo. Below the header is a table with the following data:

#	User Name	Type	Status	Last Login
1	Sanjay	Administrator	Enabled	19 August 2018, 8:30:08 PM
2	Muthu	IT Admin	Enabled	18 Feb 2019, 10:55:57 PM
3	Santosh	User	Disabled	5 Aug 2018, 11:59:31 PM
4	Anand	User	Disabled	06 August 2018, 12:56:15 AM Failed
5	Sandeep	Master	Enabled	20 Feb 2019, 1:14:40 AM
6	Dhananjay	User	Enabled	27 Aug 2018, 02:35:22 PM created
7	ram	User	Enabled	18 Feb 2019, 11:02:42 PM
8	Sundeep	Administrator	Enabled	13 October 2018, 9:54:22 PM
9	Lupin	Administrator	Enabled	18 Feb 2019, 10:23:36 PM
10	Admin	Administrator	Enabled	20 Feb 2019, 1:15:12 AM
11	MAHESH	User	Enabled	16 Oct 2018, 01:49:44 AM created

Below the table are two buttons: 'Add' and 'Type'. At the bottom of the interface is a navigation bar with buttons for 'Modify Password', 'Save', 'Wednesday, 20 Feb 2019 01:18:08 AM', 'Backup', 'Restore', 'Key', and 'Logoff'.

Press <Type>

This function is used to select User type.

Then select User name to Enable or Disable the User ID

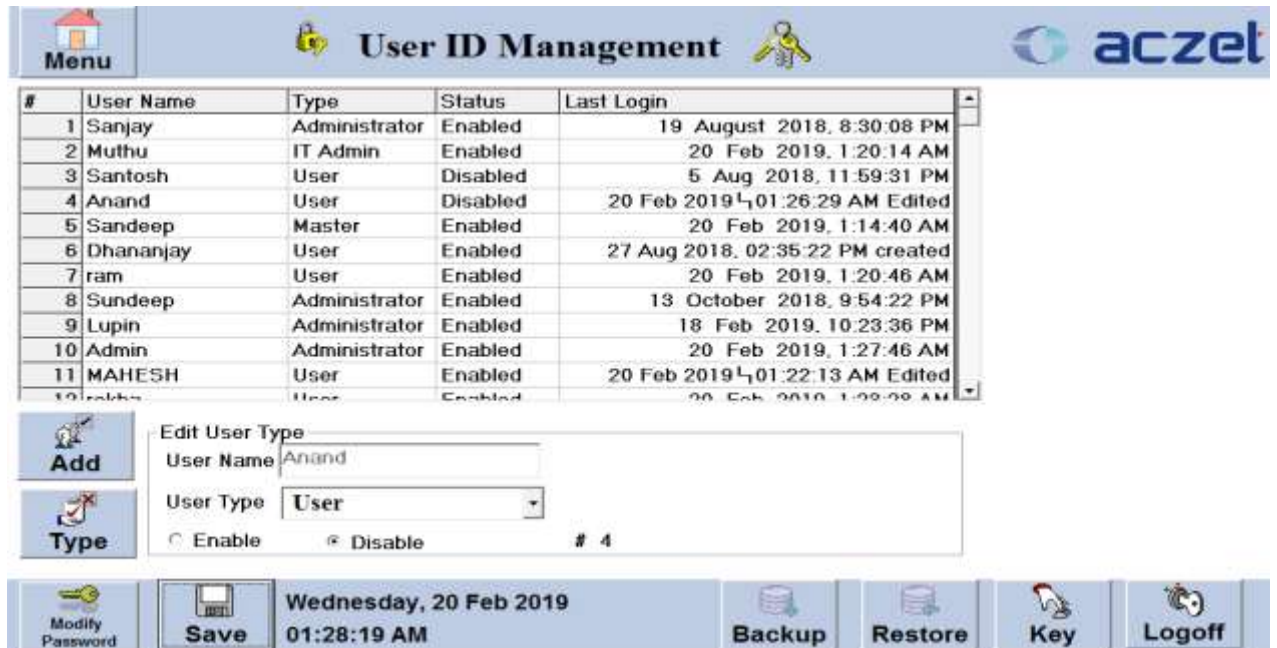

The screenshot shows the 'User ID Management' interface with the 'Edit User Type' dialog box open. The dialog box contains the following fields and options:

- Edit User Type**
- User Name**: Anand
- User Type**: User (dropdown menu)
- Enable
- Disable
- #**: 4

The table below the dialog box shows the updated status of the user 'Anand' (row 4):

#	User Name	Type	Status	Last Login
1	Sanjay	Administrator	Enabled	19 August 2018, 8:30:08 PM
2	Muthu	IT Admin	Enabled	20 Feb 2019, 1:20:14 AM
3	Santosh	User	Disabled	5 Aug 2018, 11:59:31 PM
4	Anand	User	Disabled	20 Feb 2019, 01:26:29 AM Edited
5	Sandeep	Master	Enabled	20 Feb 2019, 1:14:40 AM
6	Dhananjay	User	Enabled	27 Aug 2018, 02:35:22 PM created
7	ram	User	Enabled	20 Feb 2019, 1:20:46 AM
8	Sundeep	Administrator	Enabled	13 October 2018, 9:54:22 PM
9	Lupin	Administrator	Enabled	18 Feb 2019, 10:23:36 PM
10	Admin	Administrator	Enabled	20 Feb 2019, 1:27:46 AM
11	MAHESH	User	Enabled	20 Feb 2019, 01:22:13 AM Edited
12

The navigation bar at the bottom shows the date and time updated to 'Wednesday, 20 Feb 2019 01:28:19 AM'.

Press <Modify Password>

These function is used to modify password

First Select Type and then User Name , then enter Password and retype password.

After entry , press<SAVE> key

The screenshot displays the 'User ID Management' interface. At the top, there is a navigation bar with a 'Menu' icon, a lock icon, the title 'User ID Management', and the 'aczel' logo. Below this is a table listing users with columns for '#', 'User Name', 'Type', 'Status', and 'Last Login'. The table contains 11 rows of user data. Below the table is a form for adding a new user, with sections for 'Add' and 'Type'. The 'Add' section includes input fields for 'User Name' and 'Password'. The 'Type' section includes a dropdown menu for 'User Type' (set to 'Administrator'), a 'Retype Pw' field, and radio buttons for 'Enable' (selected) and 'Disable'. At the bottom, there is a navigation bar with icons for 'Modify Password', 'Save', 'Backup', 'Restore', 'Key', and 'Logoff'. The date and time 'Wednesday, 20 Feb 2019 01:19:07 AM' are displayed in the center of this bar.

#	User Name	Type	Status	Last Login
1	Sanjay	Administrator	Enabled	19 August 2018, 8:30:08 PM
2	Muthu	IT Admin	Enabled	18 Feb 2019, 10:55:57 PM
3	Santosh	User	Disabled	5 Aug 2018, 11:59:31 PM
4	Anand	User	Disabled	06 August 2018, 12:56:15 AM Failed
5	Sandeep	Master	Enabled	20 Feb 2019, 1:14:40 AM
6	Dhananjay	User	Enabled	27 Aug 2018, 02:35:22 PM created
7	ram	User	Enabled	18 Feb 2019, 11:02:42 PM
8	Sundeep	Administrator	Enabled	13 October 2018, 9:54:22 PM
9	Lupin	Administrator	Enabled	18 Feb 2019, 10:23:36 PM
10	Admin	Administrator	Enabled	20 Feb 2019, 1:15:12 AM
11	MAHESH	User	Enabled	16 Oct 2018, 01:49:44 AM created

Add
User Name: Password:

Type
User Type: **Administrator** Retype Pw:
 Enable Disable #

Modify Password Save Wednesday, 20 Feb 2019 01:19:07 AM Backup Restore Key Logoff

To ADD User
Press <ADD>

These function is used to Add user
First Select Type and then User Name , then enter Password and retype password.
After entry , press<SAVE> key

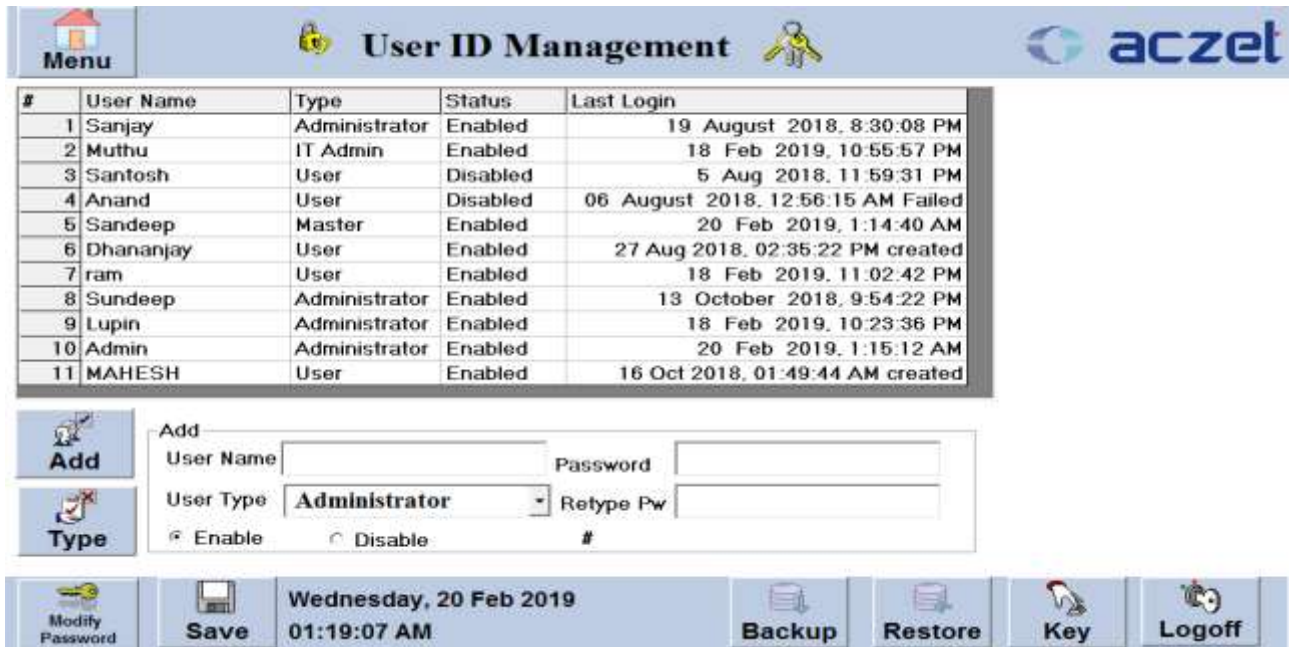

The screenshot shows the 'User ID Management' interface. At the top, there is a 'Menu' button, a lock icon, the title 'User ID Management', a key icon, and the 'aczel' logo. Below the header is a table with the following data:

#	User Name	Type	Status	Last Login
1	Sanjay	Administrator	Enabled	19 August 2018, 8:30:08 PM
2	Muthu	IT Admin	Enabled	18 Feb 2019, 10:55:57 PM
3	Santosh	User	Disabled	5 Aug 2018, 11:59:31 PM
4	Anand	User	Disabled	06 August 2018, 12:56:15 AM Failed
5	Sandeep	Master	Enabled	20 Feb 2019, 1:14:40 AM
6	Dhananjay	User	Enabled	27 Aug 2018, 02:35:22 PM created
7	ram	User	Enabled	18 Feb 2019, 11:02:42 PM
8	Sundeep	Administrator	Enabled	13 October 2018, 9:54:22 PM
9	Lupin	Administrator	Enabled	18 Feb 2019, 10:23:36 PM
10	Admin	Administrator	Enabled	20 Feb 2019, 1:15:12 AM
11	MAHESH	User	Enabled	16 Oct 2018, 01:49:44 AM created

Below the table is an 'Add' form with the following fields and options:

- Add** button
- User Name:
- Password:
- User Type: **Administrator** (dropdown menu)
- Retype Pw:
- Enable: Disable:
- #

At the bottom, there is a navigation bar with buttons: Modify Password, Save, Wednesday, 20 Feb 2019 01:19:07 AM, Backup, Restore, Key, and Logoff.

Note: Duplicate User name cannot be created . Refer below figure.

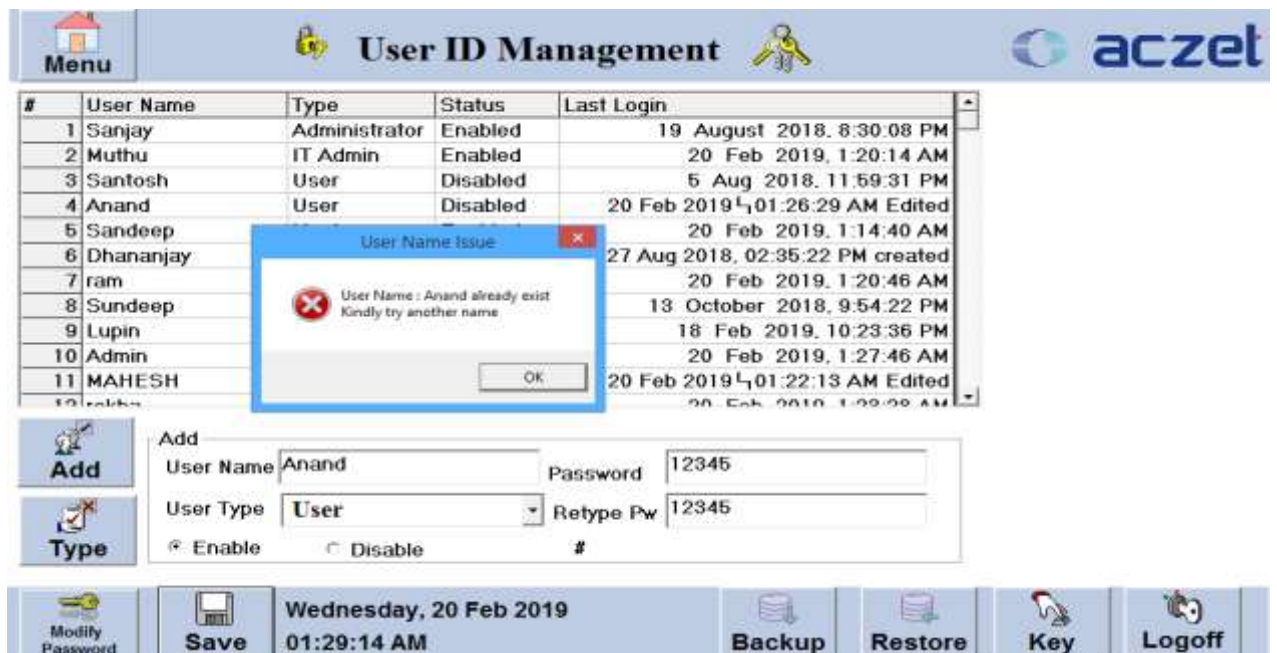

The screenshot shows the 'User ID Management' interface with an error message displayed. The error message is a dialog box titled 'User Name Issue' with the following text:

User Name : Anand already exist
Kindly try another name

The 'Add' form below the table shows the following fields and options:

- Add** button
- User Name: **Anand**
- Password: **12345**
- User Type: **User** (dropdown menu)
- Retype Pw: **12345**
- Enable: Disable:
- #

The table below the form shows the following data:

#	User Name	Type	Status	Last Login
1	Sanjay	Administrator	Enabled	19 August 2018, 8:30:08 PM
2	Muthu	IT Admin	Enabled	20 Feb 2019, 1:20:14 AM
3	Santosh	User	Disabled	5 Aug 2018, 11:59:31 PM
4	Anand	User	Disabled	20 Feb 2019, 01:26:29 AM Edited
5	Sandeep	Master	Enabled	20 Feb 2019, 1:14:40 AM
6	Dhananjay	User	Enabled	27 Aug 2018, 02:35:22 PM created
7	ram	User	Enabled	20 Feb 2019, 1:20:46 AM
8	Sundeep	Administrator	Enabled	13 October 2018, 9:54:22 PM
9	Lupin	Administrator	Enabled	18 Feb 2019, 10:23:36 PM
10	Admin	Administrator	Enabled	20 Feb 2019, 1:27:46 AM
11	MAHESH	User	Enabled	20 Feb 2019, 01:22:13 AM Edited
12

At the bottom, there is a navigation bar with buttons: Modify Password, Save, Wednesday, 20 Feb 2019 01:29:14 AM, Backup, Restore, Key, and Logoff.

To BACKUP AND RESTORE User Data

Press **BACKUP** icon to take Back up for user Data, below screen will appear.

Press **SAVE** button to save the backup data.

These Data will be stored as and in C:/BACKUP/UserDB_date/time.aczd

All Data stored will be in Encrypt format type.

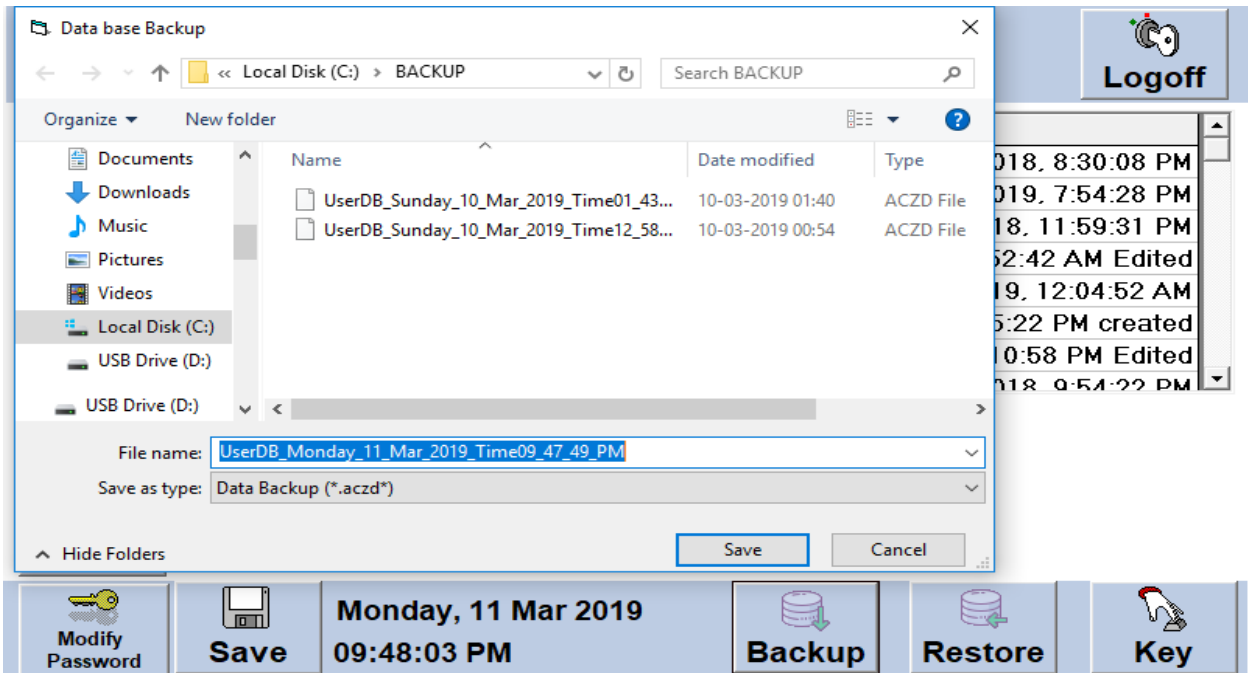

After saving the backup , below screen appears

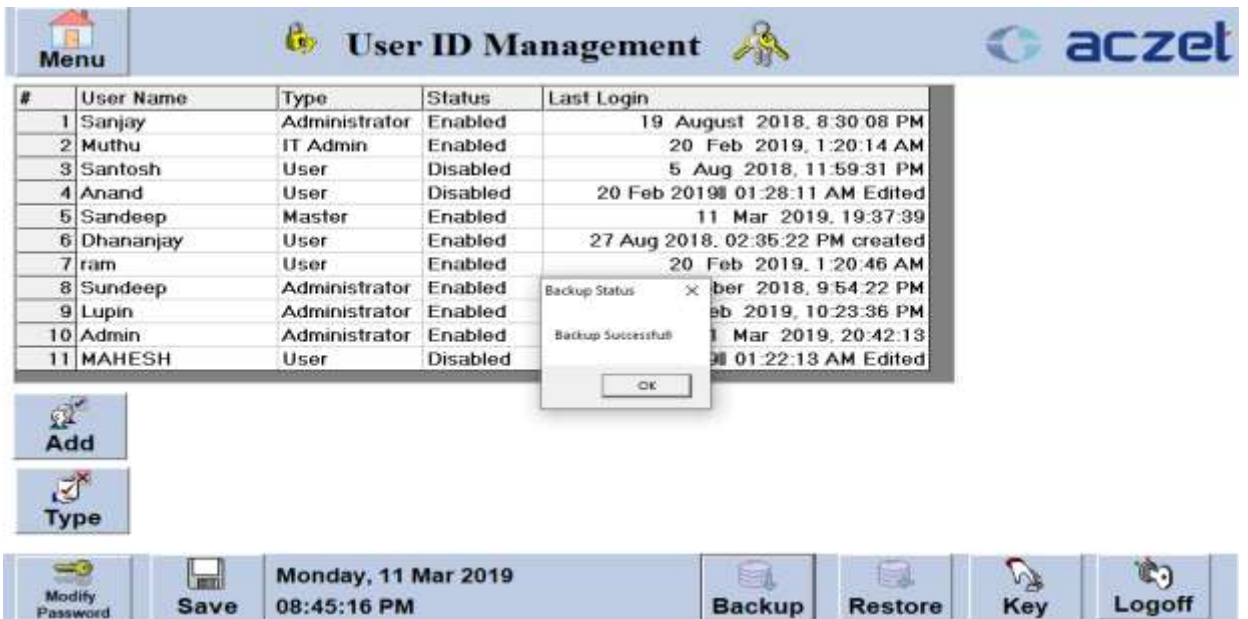
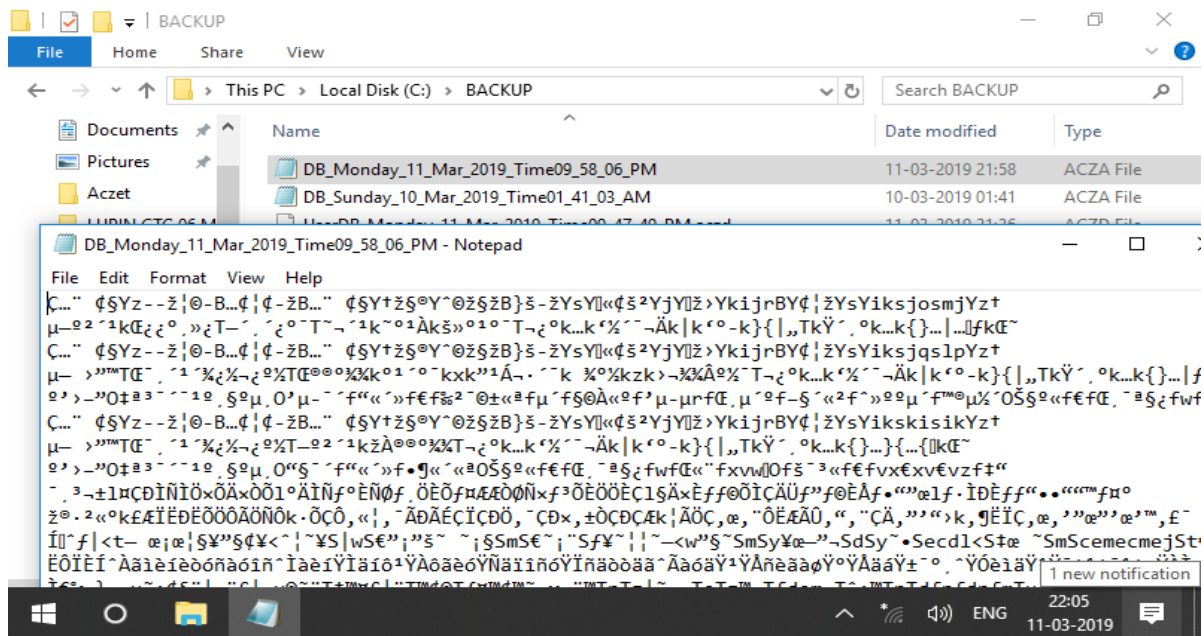

Image of Encrypted data file.



To RESTORE THE BACKUP DATA

Press RESTORE icon to RESTORE user Data, below screen will appear.

Press **Open** button to Restore the backup data.

These Data will be Restored in Current working mode.

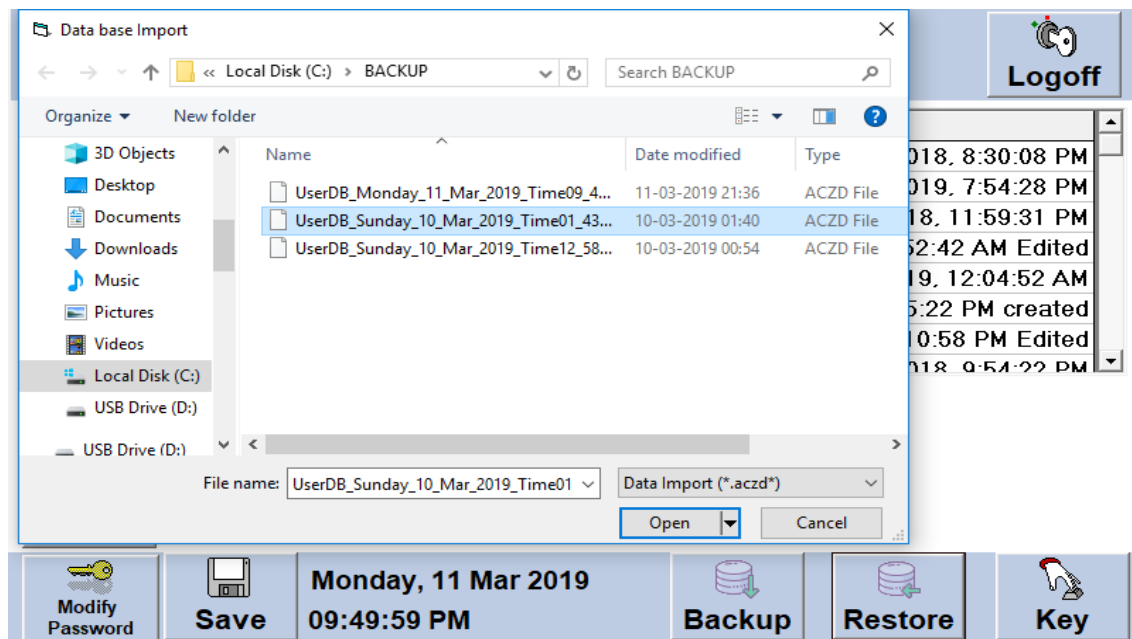

4.9 AUDIT REPORT



Press  icon for peak hold mode, following display screen appears on screen.

 **Menu**

WEIGHING SCALE AUDIT REPORT

Lupin Pharma Limited, Pune

#	User Name	Type	Status
1	Sanjay	Administrator	Enabled
2	Muthu	IT Admin	Enabled
3	Santosh	User	Disenbled
4	Anand	User	Disenbled
5	Sandeep	Master	Enabled
6	Dhananjay	User	Disenbled







...

 **Show**

Overall Operations : 1358

#	User Name	Type	Operation	Date

Thursday, 14 Mar 2019
11:43:10

 **Print**
 **Open**
 **Export**
 **Import**
 **Add**
 **Key**

a) To view /print by "User and All Period", select user name and press <SHOW > key. Following image will be display.

 **Menu**

WEIGHING SCALE AUDIT REPORT

Lupin Pharma Limited, Pune

#	User Name	Type	Status
1	Sanjay	Administrator	Enabled
2	Muthu	IT Admin	Enabled
3	Santosh	User	Disenbled
4	Anand	User	Disenbled
5	Sandeep	Master	Enabled
6	Dhananjay	User	Enabled





...

 **Show**

Overall Operations : 1041

#	User Name	Type	Operation	Date
1041	Lupin	Administrat	Audit Report Menu Opened	Mon 11 Mar 2019
1040	Lupin	Administrat	Main Menu: Audit Report Pressed	Mon 11 Mar 2019
1039	Lupin	Administrat	Main Menu Opened	Mon 11 Mar 2019
1038	Lupin	Administrat	User ID Management : Menu Pressed	Mon 11 Mar 2019
1037	Lupin	Administrat	User ID Management : Backup Button Pr	Mon 11 Mar 2019

 **Print**
Monday, 11 Mar 2019
09:51:42 PM

 **Export**
 **Import**
 **Add**
 **Key**

b) To view /print by **User and specific date** , select user name , specify period start date and end date and press **<SHOW >** key.

Following image will be display.

WEIGHING SCALE AUDIT REPORT

Lupin Pharma Limited, Pune

#	User Name	Type	Status
3	Santosh	User	Disenbled
4	Anand	User	Disenbled
5	Sandeep	Master	Enabled
6	Dhananjay	User	Enabled
7	ram	User	Disenbled
8	Sundeep	Administrator	Enabled

Specific User Dhananjay

All Period

Show

Overall Operations : 42 / 1041

#	User Name	Type	Operation	Date
1	Dhananjay	User	Audit Menu: Exit	Wed 6 Mar 2019
2	Dhananjay	User	Audit Menu : C:\Aczet\DB_Wednesday_6	Wed 6 Mar 2019
3	Dhananjay	User	Audit Menu : Export Button Pressed	Wed 6 Mar 2019
4	Dhananjay	User	Audit Report - Overall Operations : 4 / 1	Wed 6 Mar 2019
5	Dhananjay	User	Audit Report : Show button Pressed	Wed 6 Mar 2019

Print

Monday, 11 Mar 2019
09:52:46 PM

Export

Import

Add

Key

WEIGHING SCALE AUDIT REPORT

Lupin Pharma Limited, Pune

#	User Name	Type	Status
3	Santosh	User	Disenbled
4	Anand	User	Disenbled
5	Sandeep	Master	Enabled
6	Dhananjay	User	Enabled
7	ram	User	Disenbled

Specific User Dhananjay

Specific Period

Show

Overall Operations : 42 / 1041

From **February 2019** February 2019

Sun	Mon	Tue	Wed	Thu	Fri	Sat
27	28	29	30	31	1	2
3	4	5	6	7	8	9
10	11	12	13	14	15	16
17	18	19	20	21	22	23
24	25	26	27	28	1	2
3	4	5	6	7	8	9

To **March 2019** March 2019

Sun	Mon	Tue	Wed	Thu	Fri	Sat
24	25	26	27	28	1	2
3	4	5	6	7	8	9
10	11	12	13	14	15	16
17	18	19	20	21	22	23
24	25	26	27	28	29	30
3	4	5	6	7	8	9

#	User Name	Type	Operation	Date
				Wed 6 Mar 2019
				Wed 6 Mar 2019
				Wed 6 Mar 2019
				Wed 6 Mar 2019
				Wed 6 Mar 2019

Print

09:55:52 PM

Export

Import

Add

Key

To PRINT Aduit report

Press <Print> key, below screen appears.
Select printer and print the report.

Note: First system should be attached to the Printer and Printer name to be Added .

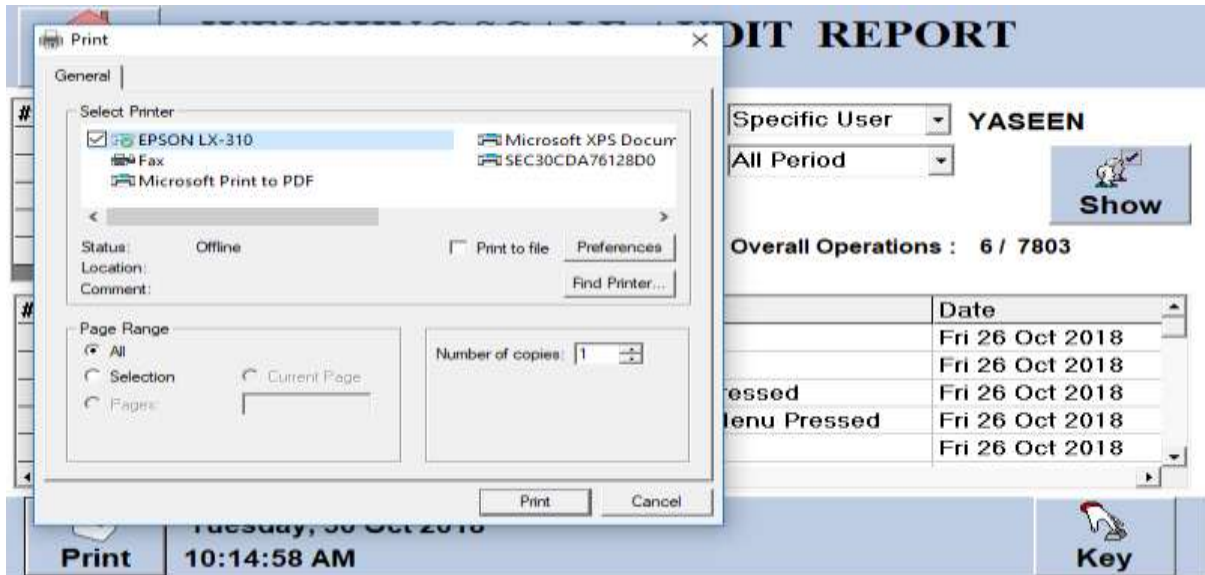

To SAVE Aduit report

Press <Print> key, below screen appears.

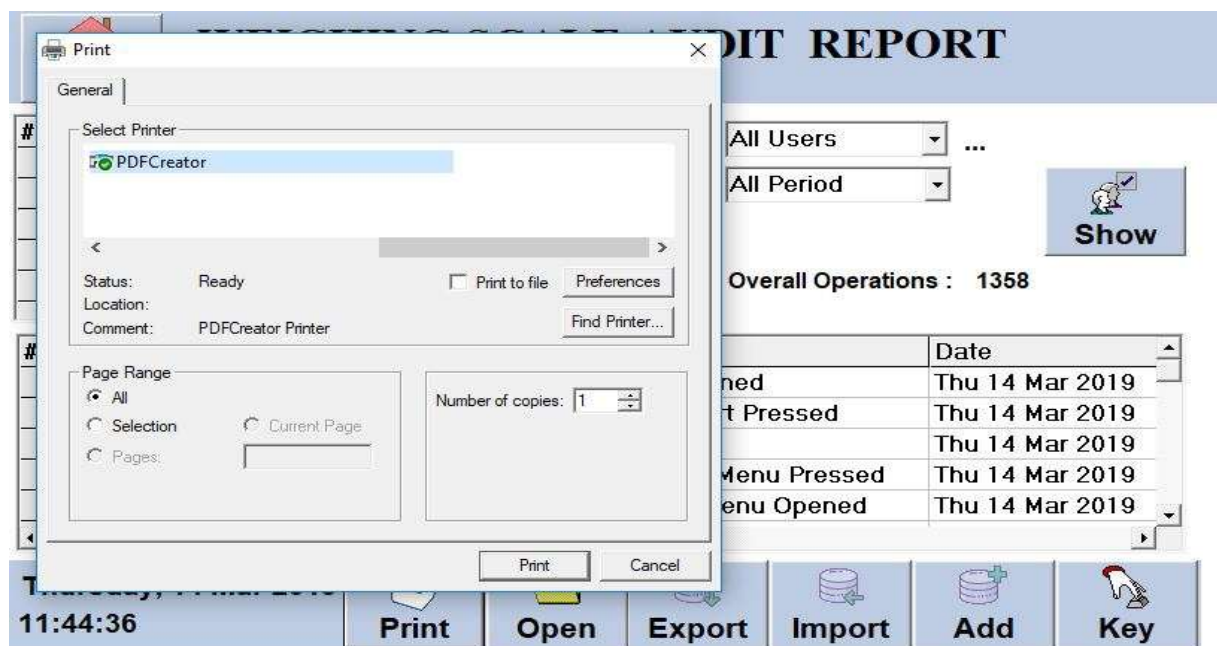

ALL AUDIT DATA WILL BE SAVED IN C:/DATA

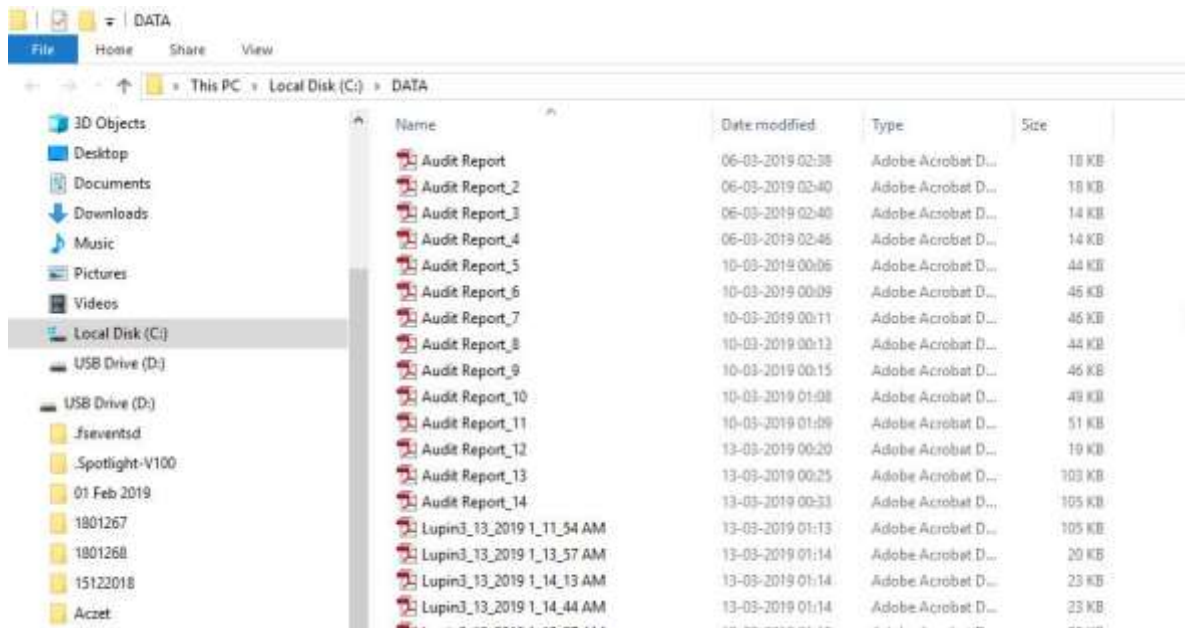

Press OPEN icon to view Audit trail Report

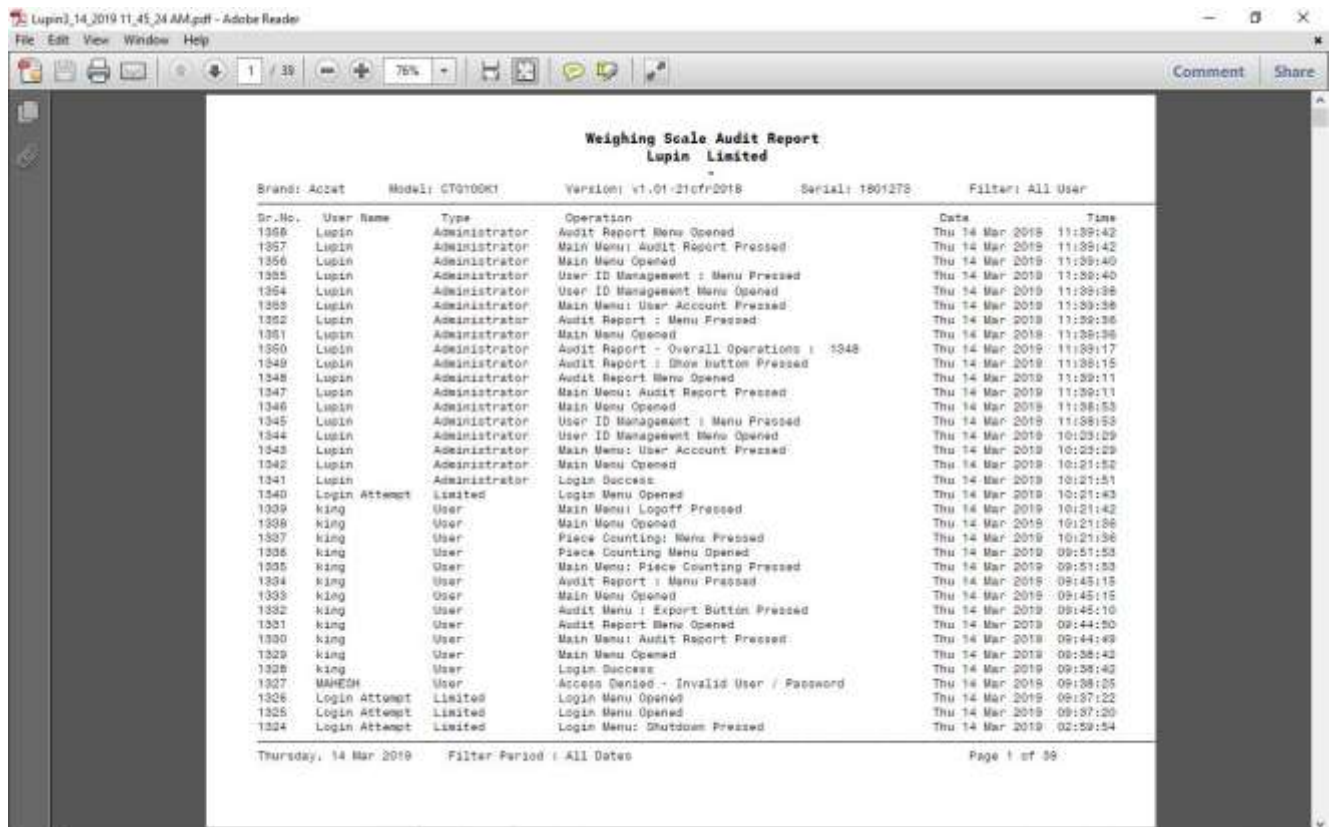

To BACKUP AND RESTORE Audit Trail Data

Press **BACKUP** icon to take Back up for user Data, below screen will appear.

Press **SAVE** button to save the backup data.

These Data will be stored as and in C:/BACKUP/DB_date/time.acza

All Data stored will be in Encrypt format type.

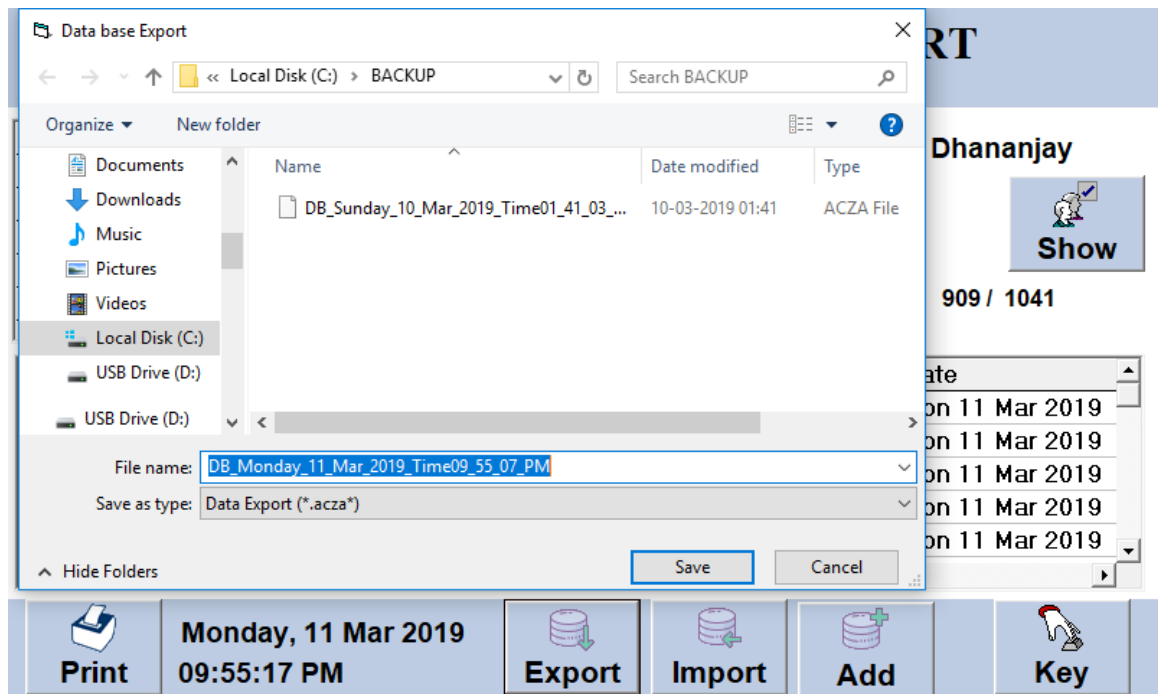

After saving the backup , below screen appears

The screenshot displays the 'WEIGHING SCALE AUDIT REPORT' interface for Lupin Pharma Limited, Pune. The user 'Dhananjay' is logged in, and the overall operations are 909 / 1041. A table lists users with their IDs, names, types, and statuses. An 'Export Status' dialog box is open, indicating 'Export Successful'. Below the user list, another table shows the audit trail with columns for ID, User Name, Type, Operation, and Date. The navigation bar at the bottom shows the date 'Monday, 11 Mar 2019 09:58:15 PM' and buttons for 'Print', 'Export', 'Import', 'Add', and 'Key'.

#	User Name	Type	Status
3	Santosh	User	Disenbled
4	Anand	User	Disenbled
5	Sandeep	Master	Enabled
6	Dhananjay	User	Enabled
7	ram	User	Disenbled
8	Sundeep	Administrator	Enabled

#	User Name	Type	Opera	Date
1	Lupin	Administrat	Audit	Mon 11 Mar 2019
2	Lupin	Administrat	Main t	Mon 11 Mar 2019
3	Lupin	Administrat	Main t	Mon 11 Mar 2019
4	Lupin	Administrat	User ID Management : Menu Pressed	Mon 11 Mar 2019
5	Lupin	Administrat	User ID Management : Backup Button Pr	Mon 11 Mar 2019

To RESTORE THE Audit Trail Data

Press RESTORE icon to RESTORE user Data, below screen will appear.

Press **Open** button to Restore the backup data.

These Data will be Restored in Current working mode.

The screenshot shows a 'Data base Import' dialog box with the following details:

- Location: Local Disk (C:) > BACKUP
- File Name: DB_Sunday_10_Mar_2019_Time01_41_03_...
- Date modified: 10-03-2019 01:41
- Type: ACZA File
- File format: Data Import (*.acza*)

The background interface includes a 'Print' button, a date/time display 'Monday, 11 Mar 2019 09:57:18 PM', and buttons for 'Export', 'Import', 'Add', and 'Key'. A report for 'Dhananjay' is visible with a 'Show' button and a list of dates: 'on 11 Mar 2019'.

The screenshot displays the 'WEIGHING SCALE AUDIT REPORT' for 'Lupin Pharma Limited, Pune'. It features a 'Menu' button and a 'Show' button. The main content includes a user list table and an audit trail table.

#	User Name	Type	Status
3	Santosh	User	Disenabled
4	Anand	User	Disenabled
5	Sandeep	Master	Enabled
6	Dhananjay	User	Enabled
7	ram	User	
8	Sundeep	Administrato	

An 'Import Status' dialog box is open, showing 'Data Imported : 1059' and an 'OK' button.

#	User Name	Type	Oper	Date
1	Lupin	Administrato	Audit	Mon 11 Mar 2019
2	Lupin	Administrato	Main	Mon 11 Mar 2019
3	Lupin	Administrato	Main	Mon 11 Mar 2019
4	Lupin	Administrato	User ID Management : Menu Pressed	Mon 11 Mar 2019
5	Lupin	Administrato	User ID Management : Backup Button Pr	Mon 11 Mar 2019

The interface also includes a 'Print' button, a date/time display 'Monday, 11 Mar 2019 09:59:17 PM', and buttons for 'Export', 'Import', 'Add', and 'Key'. A report for 'Dhananjay' is visible with a 'Show' button and the text 'Overall Operations : 1059'.



Shutdown

- Shutdown key is used to power OFF the machine and this key is present only on Main menu screen of the balance.
- Press this key to switch **OFF** the balance.
- Once the balance is switched **OFF** with the screen, Now **OFF** the main power Supply and Disconnect the Adaptors from the balance and Display.
- Turn OFF the main power Supply and Disconnect the Adaptors .
- Turn OFF the weighing scale and Turn OFF the Mains supply.

Note: 1.**DONOT** switch **OFF** the micro balance direct from power source .
2.**DONOT** overload the balance above rated capacity.
3. Always keep balance in hard and level surface.
4. Avoid direct wind flow or Air flow on the balance.

LIMITED WARRANTY

ACZET products are warranted against defects in materials and workmanship from the date of delivery through the duration of the warranty period. During the warranty period Aczet will repair, or, at its option, replace any components that proves to be defective at no charge, provided that the product is returned, freight prepaid, to ACZET.

This warranty does not apply if the product has been damaged by accident or misuse, exposed to radioactive or corrosive materials, has foreign material penetrating to the inside of the product, or as a result of service or modification by other than ACZET. In lieu of a properly returned warranty registration card, the warranty period shall begin on the date of shipment to the authorized dealer. No other express or implied warranty is given by Aczet Pvt. Ltd.

As warranty legislation differs from state to state and country to country, please contact Aczet or your local ACZET dealer for further details.

ACZET service center will repair the product free of charge subject to terms & condition mentioned below.

TERMS & CONDITION

1.It covers only Check weigher purchased from authorized channel and does not covers accessories like conveyer belt, Adaptor, tower lamp etc

2.It does not cover the product of which model and serial number has been altered, removed or defaced and / or is open by unauthorized person and found void sticker has been tampered.

3.This warranty is non-transferable and applicable only to first end user purchasing the product from authorized dealer.

4.For repair based on this warranty you need to hand over this product or send this product to address mentioned in warranty card in original packing, enclosing copy of this warranty card.

5.Aczet Pvt. Ltd. shall not be liable for any consequential damages.

WARRANTY REGISTRATION



ACZET PVT.LTD.
E2, Plot No. 15, WICEL Estate,
Opp. Seepz Gate No. 1,
Andheri (E), Mumbai 400 093
E-mail : service@aczet.com
web: www.aczet.com
Tel. No. : +91 22 4243 7700
Fax No. : +91 22 4243 7800

NAME :-

ADDRESS :-

TEL NO. :- MODEL NO. :-

SERIAL NO. :- PURCHASE DATE :-

BRANCH / DISTRIBUTOR / DEALER CONTACT DETAILS

.....

STAMP / SIGN

WARRANTY PERIOD :-

Owners Signature / Date

SEND YOUR WARRANTY CARD DULY FILL TO ABOVE ADDRESS FOR REGISTRATION