

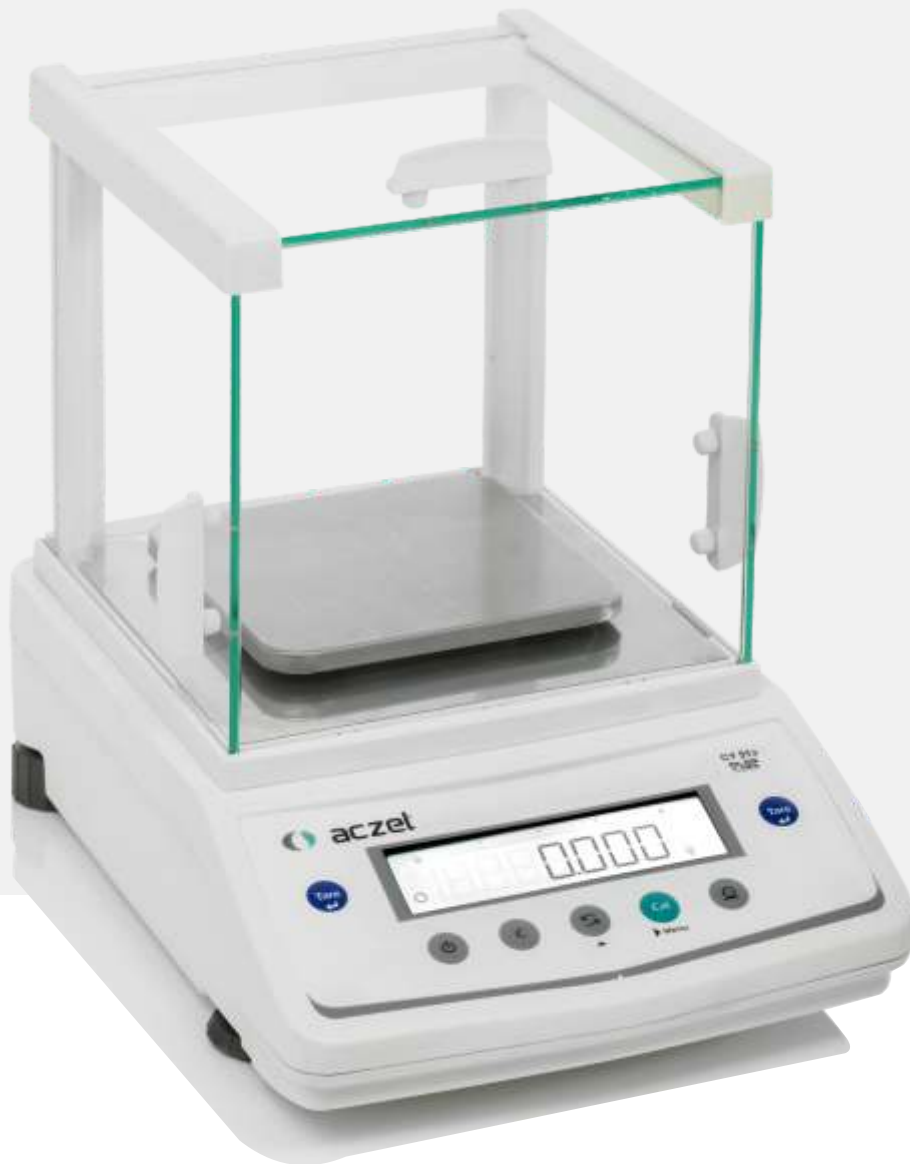

Laboratory Balances & Scales

Solution Simplified



www.aczel.com

Precision Balance CY-C Series

"Unmatched Precision, Reliable Results"

Precision Balances Perfect Measurements Guaranteed

CY-C Professional Level Series

11 Easy-to-use Built-in-Applications

Precise mass measurements and a dependable precision balance are must-have tools in any laboratory or setting that demands accuracy. The line of Precision Balances that we offer is meticulously engineered to provide highly accurate readings even for the minutest weight increments. Our Precision Balances are available in a wide range of capacities, from 120 g up to 3000 g, with a readability of 0.001 gm, catering to diverse weighing needs. Whether it's small-scale research or larger industrial applications, our Precision Balances cover the entire spectrum of precision operations..



- Piece Counting
- % Weighing
- Formulation
- Pipette - Check
- Animal Weighing
- Custom Unit
- Check Weighing
- Totalization
- Density
- Statistics
- Below Hook

Reliable and precise results



The Mono-Tech technology sensor truly stands out with its unparalleled design based on electromagnetic force compensation (EMFC). Its exceptional performance meets the highest international standards. I am truly impressed by its unique features and the results it delivers.

Strong and Sturdy Construction



Ensures reliability and durability with its strong construction and solid performance, perfect for long-term use.

Easy-to-Read LCD Screen



Easy-to-Read LCD ScreenThe balance is equipped with a large LCD backlit screen that ensures easy visibility in any lighting conditions. The backlit feature illuminates the screen, making it readable even in low-light environments.

Efficient Functioning



Designed with a spacious glass draft shield 3 side opening and an IP54 protection class for efficient and safe operation, and protection against dust and water splashes.

Easy Leveling



Easy LevelingSimply adjust the feet of the balance until the level indicator shows that the air bubble is centered. This ensures accurate measurements.

Efficient Communication



Features RS 232 communication, allowing for error-free documentation, ensuring accurate and reliable data transfer Pc or printer.

Precision Balances Perfect Measurements Guaranteed

CY-C Professional Level Series

Revolution in Mass Measurement Quantity

Our Precision balance sets a new benchmark for mass measurement quality with the best weighing accuracy and $sd \leq 1d$ repeatability. We adhere to strict USP requirements (chapters 41 and 1251) to ensure the highest level of quality in our measurements.

Monitored Ambient Conditions

A unique ambient conditions monitoring feature is applied to supervise environmental conditions at the balance workplace.

Overload Protection

Monitor the built-in display for capacity tracking to prevent overloading the weighing cell.

















Internal Calibration Professional Level CY-C Series

Motorized built-in weight internal calibration ensures precise weighing performance in any condition.

Environmental influence Professional Level CY-C Series

The PSAC Cal. function ensures accurate measurements in any condition. It performs automatic internal calibration based on time or temperature changes to maintain precision.

15 Significant Features

- Mono-Tech 
- Internal Cal 
- PSAC Cal 
- External Cal 
- GLP/GMP 
- Auto Off 
- Capacity Tracker 
- Over Load Prot. 
- IP 54 
- Connectivity 
- Opt. Connectivity 
- Windows Comm. 
- Levelling 
- Anti-Theft lock 
- Protective Cover 

GLP Documentation



Balance includes a built-in GLP Documentation feature for easy input of essential information. Ensures compliance with GMP/GLP/ISO regulations, even without printer connection.

Effortless Cleaning



Effortless Cleaning The draft shields can be easily dismantled and assembled, making it really convenient to keep the balance clean and tidy.

Below Balance Weighing is ideal for



- Oversized objects that would not be able to easily fit/balance on the scale pan.
- Irregularly shaped objects that have a hard time lying flat.
- Hot or cold materials whose temperature coefficient would affect the electronics of the scale.
- Magnetic materials that would interfere with the sensor and inner workings of the scale

Application Industries

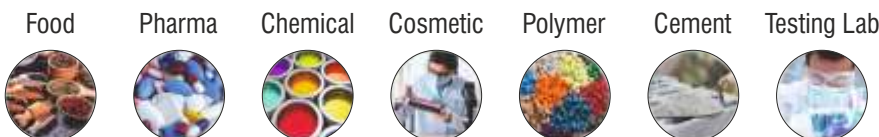

Professional Series	CY 123C	CY 223C	CY 323C	CY 363C	CY 423C	CY 513C
Maximum Capacity	120 g	220 g	320 g	360 g	420 g	510 g
Minimum load	0.02 g	0.02 g	0.02 g	0.02 g	0.02 g	0.02 g
Readability	0.001 g	0.001 g	0.001 g	0.001 g	0.001 g	0.001 g
Repeatability	0.001 g	0.001 g	0.001 g	0.001 g	0.001 g	0.001 g
Linearity (±)	0.002 g	0.002 g	0.002 g	0.002 g	0.002 g	0.002 g
Tare Range (Subtractive)	-120 g	-220 g	-320 g	-360 g	-420 g	-510 g
Minimum Weight (USP, 0.1%, typical)	1 g					
Minimum weight (U=1%, typical)	0.1 g					
Pan Size (mm)	128 x 128					
Response Time	2 - 3 Sec.					
Display	Alpha Numeric Backlit LCD Display					
Calibration	Motorised Internal Calibration					
Units of measure	gm, mg, ct, GN, mo, oz, dwt, t1T, t1H, t1S, mom, Bat, MS					
Operating Temp.	18° to 30°C					
Sensitivity Drift.	± 2ppm (2 x 10 / °C)					
Interface	RS 232C Optional USB (Windows direct communication).					
Application Modes	PCS, % Weighing, Animal / Dynamic Weighing, Check Weighing, Automatic Density Determination, Formulation Automatic Statistic Calculator etc.					
Power Supply	DC Adaptor, input 100 ~ 240 0.8A output 13V / 15.A, 50-60Hz					
Compliance	ISO, GLP / GMP & USP					
Balance Size (W x D X H)	342.5 x 212 x 271 mm / Chamber Height 169.5mm					
Weight Approx	7.5 kg					

Professional Series	CY 623C	CY 723C	CY 1003C	CY 2003C	CY 3003C
Maximum Capacity	620 g	720 g	1000 g	2000 g	3000 g
Minimum load	0.02 g	0.02 g	0.02 g	0.02 g	0.02 g
Readability	0.001 g	0.001 g	0.001 g	0.001 g	0.001 g
Repeatability	0.001 g	0.001 g	0.002 g	0.003 g	0.003 g
Linearity (±)	0.002 g	0.002 g	0.005 g	0.005 g	0.005 g
Tare Range (Subtractive)	-620 g	-720 g	-1000 g	-2000 g	-3000 g
Minimum Weight (USP, 0.1%, typical)	1 g				
Minimum weight (U=1%, typical)	100 mg				
Pan Size (mm)	128 x 128				
Response Time	2 - 3 Sec.				
Display	Alpha Numeric Backlit LCD Display				
Calibration	Motorised Internal Calibration				
Units of measure	gm, mg, ct, GN, mo, oz, dwt, t1T, t1H, t1S, mom, Bat, MS				
Operating Temp.	18° to 30°C				
Sensitivity Drift.	± 2ppm (2 x 10 / °C)				
Interface	RS 232C Optional USB (Windows direct communication).				
Application Modes	PCS, % Weighing, Animal / Dynamic Weighing, Check Weighing, Automatic Density Determination, Formulation Automatic Statistic Calculator etc.				
Power Supply	DC Adaptor, input 100 ~ 240 0.8A output 13V / 15.A, 50-60Hz				
Compliance	ISO, GLP / GMP & USP				
Balance Size (W x D X H)	342.5 x 212 x 271 mm / Chamber Height 169.5mm				
Weight Approx	7.5 kg				

Accessories

- Data Printer - CPR 02 Dot Matrix
- Density Kit - CDK01
- Test Weight - E1, E2, F1
- Anti-Vibration Pad - VRD-03
- Battery Backup - LBA-X 01
- Remote Display - SRD - 01
- IQ, OQ, PQ Document - LBA-X 20
- Interface Cable - LBA-X 15
- Anti-Thief Lock - LBA-X 16
- Specific Gravity Stand - LBA-X 13.B

Software

21 CFR PART 11 PC Software

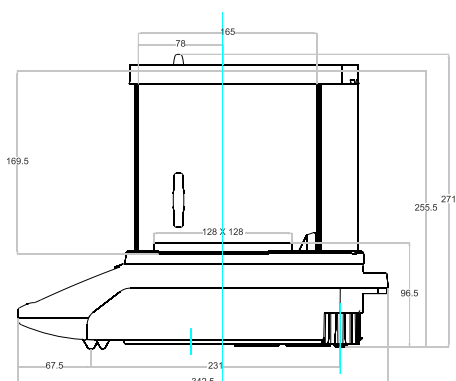

Draft Shield

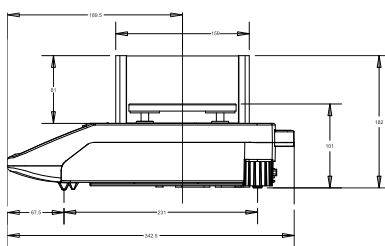

Wind Shield

