

Overall dimensions

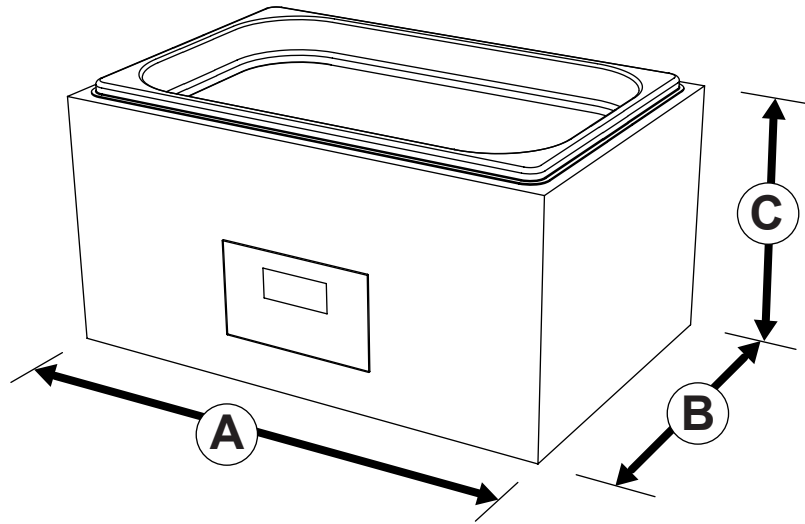

Packed weight: 11kg
Product weight: 9kg

Packed dimensions;
A 445mm
B 700mm
C 375mm

Product dimensions;
A 335mm
B 590mm
C 275mm

Working Area

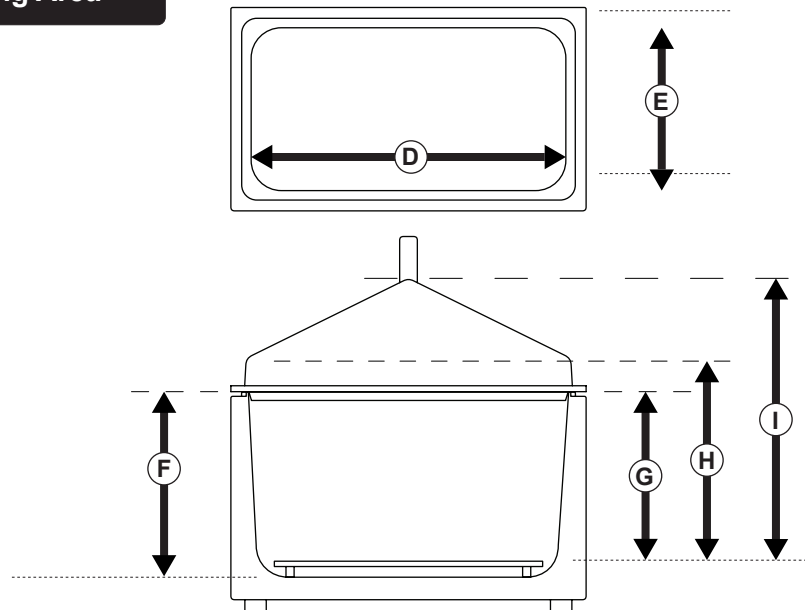

D	298mm (at opening)
D	278mm (at tray height)
E	501mm (at opening)
E	481mm (at tray height)
F	200mm
G	182mm
H	200mm
I	284mm

Vessel capacity with tank lid

	Diameter	Height	Max. no in bath
Duran 21-801: 100ml	56mm	105mm	37s
Duran 21-801: 150ml	62mm	110mm	28
Duran 21-801: 250ml	70mm	143mm	24s
Duran 21-801: 500ml	86mm	181mm	15
Duran 21-801: 750ml	95mm	203mm	12s
Duran 21-801: 1000ml	101mm	230mm	8
Duran 21-801: 2000ml	136mm	265mm	3

Vessel capacity without tank lid

	Diameter	Height	Max. no in bath
Duran 21-801: 100ml	56mm	105mm	37s
Duran 21-801: 150ml	62mm	110mm	28
Duran 21-801: 250ml	70mm	143mm	24s
Duran 21-801: 500ml	86mm	181mm	15
Duran 21-801: 750ml	95mm	203mm	12s
Duran 21-801: 1000ml	101mm	230mm	12s
Duran 21-801: 2000ml	136mm	265mm	6

s - staggered to fit maximum number

Typical performance data

Heat up time

Heat up time from 20°C

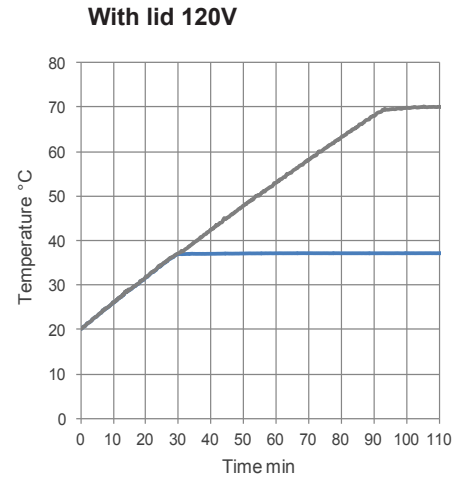
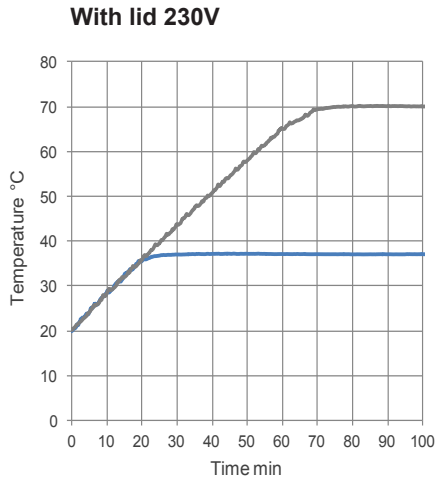

Energy Consumption

Consumption is measured over a 6 hour period when the bath is controlling at set temperature. All figures are for guidance only. Consumption figures may vary due to factors such as ambient temperature, vessel loading and ventilation.

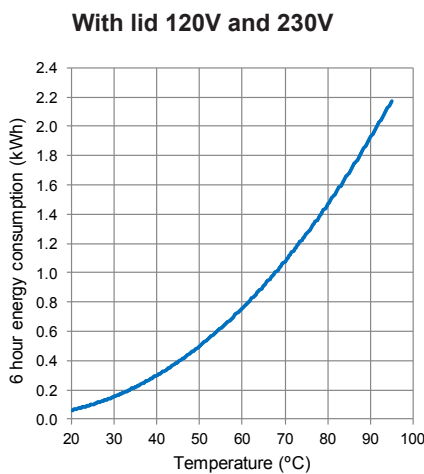

Energy Consumption

Testing to DIN 12876

