

Overall dimensions

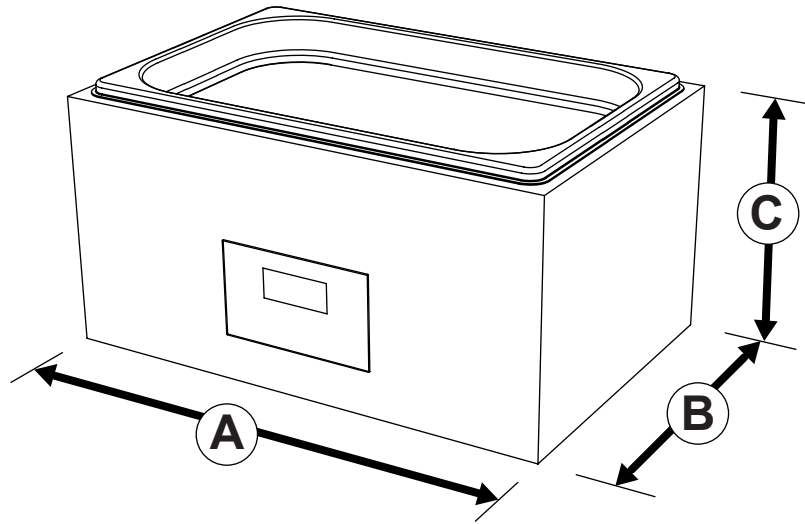

Packed weight: 7.5kg
Product weight: 6kg

Packed dimensions;
A 470mm
B 475mm
C 325mm

Product dimensions;
A 360mm
B 380mm
C 225mm

Working Area

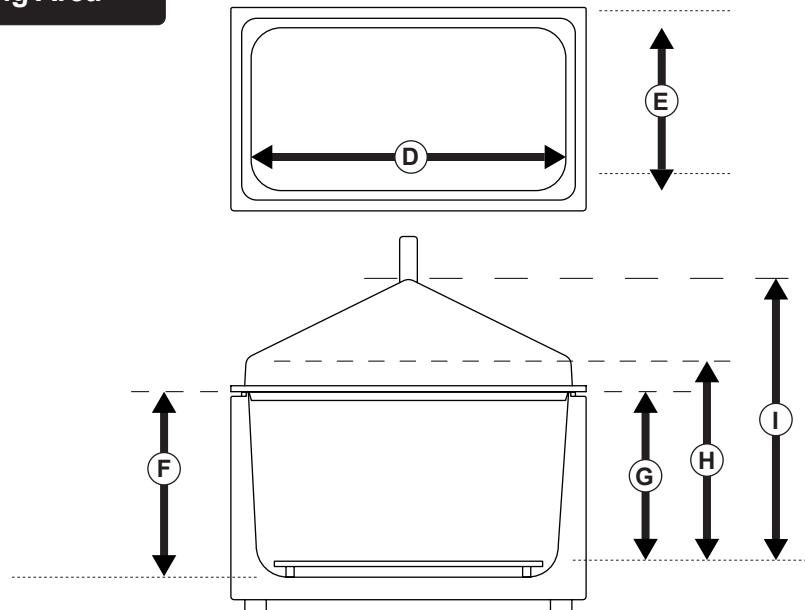

D	323mm (at opening)
D	306mm (at tray height)
E	298mm (at opening)
E	281mm (at tray height)
F	150mm
G	132mm
H	150mm
I	241mm

Vessel capacity with tank lid

	Diameter	Height	Max. no in bath
Duran 21-801: 100ml	56mm	105mm	23s
Duran 21-801: 150ml	62mm	110mm	16
Duran 21-801: 250ml	70mm	143mm	14s
Duran 21-801: 500ml	86mm	181mm	8s
Duran 21-801: 750ml	95mm	203mm	3s
Duran 21-801: 1000ml	101mm	230mm	2
Duran 21-801: 2000ml	136mm	265mm	0

Vessel capacity without tank lid

	Diameter	Height	Max. no in bath
Duran 21-801: 100ml	56mm	105mm	23s
Duran 21-801: 150ml	62mm	110mm	16
Duran 21-801: 250ml	70mm	143mm	14s
Duran 21-801: 500ml	86mm	181mm	9
Duran 21-801: 750ml	95mm	203mm	8s
Duran 21-801: 1000ml	101mm	230mm	5s
Duran 21-801: 2000ml	136mm	265mm	4

s - staggered to fit maximum number

Typical performance data

Heat up time

Without lid

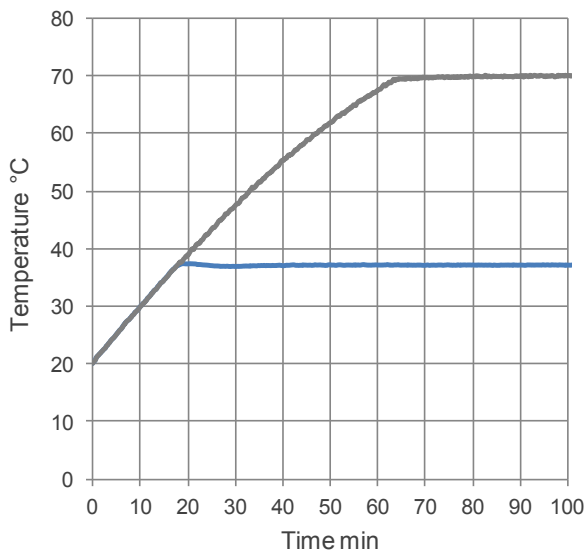

With lid

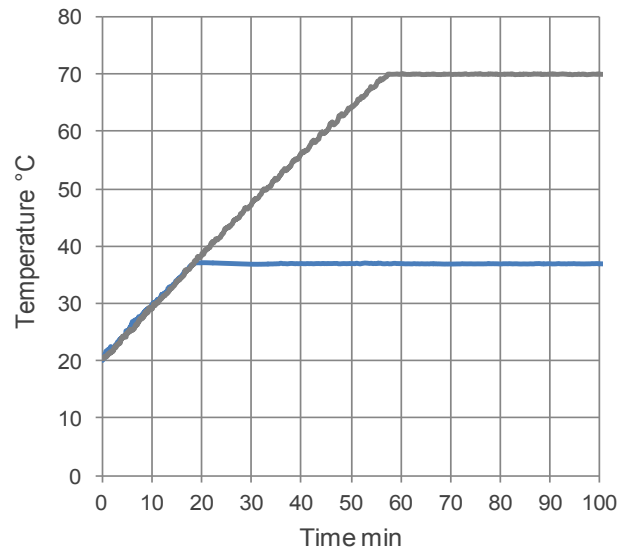

Heat up time from 20°C

Energy consumption

Without lid

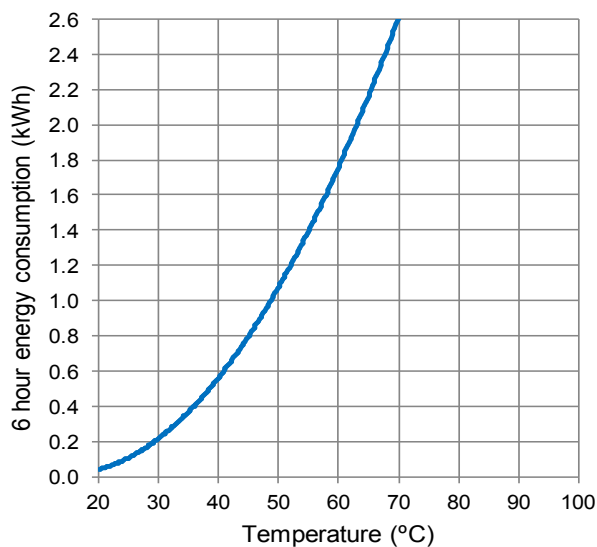

With lid

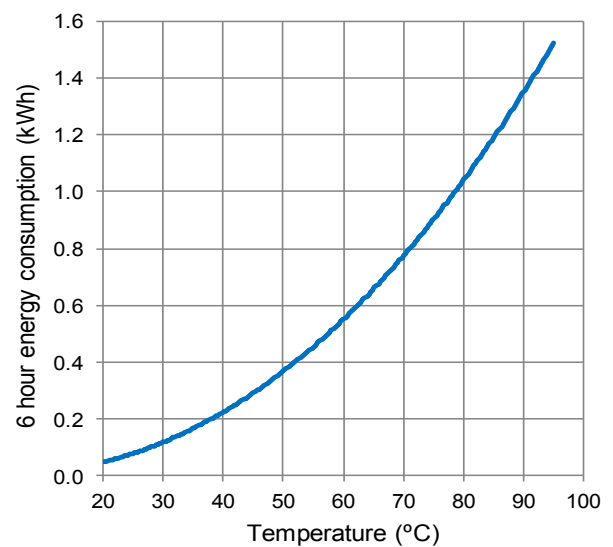

Consumption is measured over a 6 hour period when the bath is controlling at set temperature. All figures are for guidance only. Consumption figures may vary due to factors such as ambient temperature, vessel loading and ventilation.