

Montage des Auslegers H 16.3 mit Stativstab H 16 V Assembly of extension H 16.3 and support rod H 16 V



Beachten Sie die Betriebsanleitung
 des Reaktionsblockes!

*Observe the operating instructions of
 the Flask Carrier!*

Lieferumfang Delivery scope

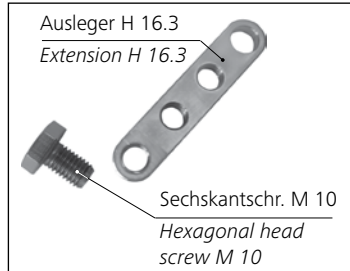

Benötigtes Werkzeug Needed tools

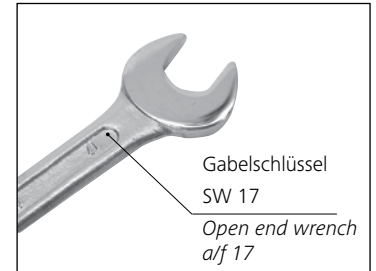

Montage: Assembly:

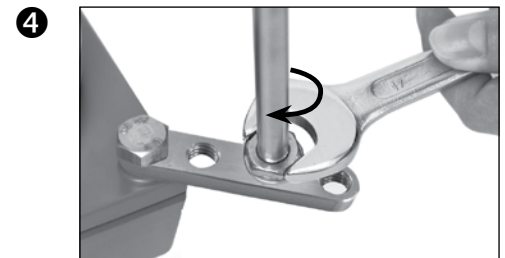
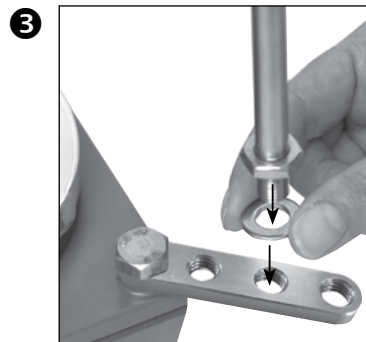
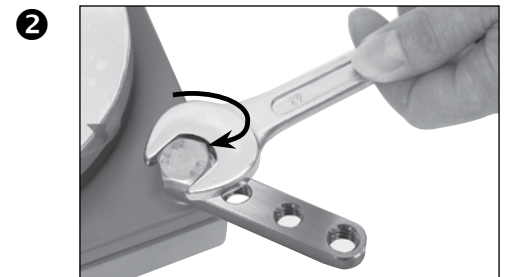
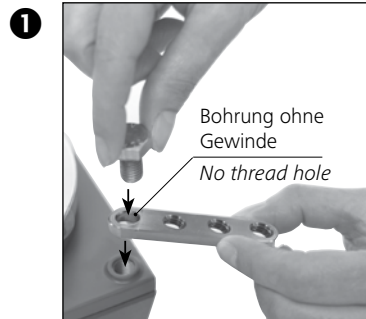

Richtig montierter Ausleger Extension assembled correctly

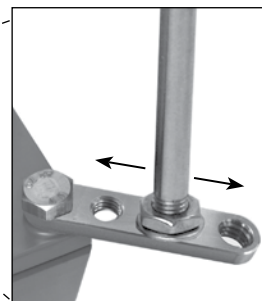

Hinweis: Richten Sie die H16V-Position an dem jeweiligen
 Reaktionsblock aus.

Note: Adjust H 16 V position according to the Flask Carrier.

